

# PERROBELL

1985 - 2022



**PEROBELL  
CLASSICS**





*A Luis Ignacio Sánchez,  
alma máter de Perobell.*

Perobell is a  
promise of  
comfort,  
softness,  
and quality.

<sup>EN</sup> Would you like to attend a live Beatles concert? Read the fourth installment of Millennium written by Larson? Listen to Queen's 2021 album? Some classics are condemned to live only in our memory.

Fortunately, others receive the gift of a second chance and come back to life with the unstoppable energy of those who have crossed borders sailing through storms and calm seas, and have survived. They are privileged travelers whom time has allowed to pass without touching them. They return as vigorous and attractive as at the beginning of their journey.

This is PEROBELL, which reappears as brilliant and powerful as the brand associated with the history of Spanish design has always been. The mythical firm of upholstered seats returns from the hand of one of its founders who participated in its creation back in 1978. As commercial director and responsible for the image and product of the firm, he has accompanied the ups and downs of PEROBELL from the beginning, being the most visible face at trade fairs, cultural events and company management. Now, it is the guarantee that the company recovers its essence to offer it to a market that likes high-level timeless designs.

As always, behind PEROBELL there is a cast of designers who forged the legend of an unforgettable catalogue: Pensi, Lievore, Rifé, Codina... the authors of an unbeatable repertoire of classics that re-equip 21st century environments. Premier, Chocolate, Protos... are names that are part of the design history of this country. That traveled beyond our borders to seduce lovers of contemporary interior design from all over the world.

Why now PEROBELL? Because behind a great brand there are people. And circumstances, difficulties, joys... but, above all, there is a background of illusion deposited in each piece with the little red label. The pride of a way of understanding design that goes through production quality and seriousness of service. A classic returns. PEROBELL returns.

Marcel Benedito

<sup>ES</sup> *¿Te gustaría asistir a un concierto de Los Beatles en vivo? ¿Leer la cuarta entrega de Millennium escrita por Larson? ¿Escuchar el álbum 2021 de Queen? Algunos clásicos están condenados a vivir únicamente en nuestra memoria.*

*Afortunadamente, otros reciben el don de una segunda oportunidad y vuelven a la vida con la energía imparable de quienes han atravesado fronteras navegando con tormentas y mares en calma, y han sobrevivido. Son viajeros privilegiados a los que el tiempo ha dejado pasar sin tocarlos. Vuelven tan vigorosos y atractivos como al principio de su trayecto.*

*Así es PEROBELL, que reaparece tan brillante y poderosa como siempre ha sido la marca asociada a la historia del diseño español. La mítica firma de asientos tapizados vuelve de la mano de uno de sus fundadores quien participó en su creación allá por 1978. Como director comercial y responsable de la imagen y producto de la firma, ha acompañado los avatares de PEROBELL desde el principio, siendo la cara más visible en ferias comerciales, eventos culturales y gestión de la compañía. Ahora, es la garantía de que la empresa recupera su esencia para ofrecerla a un mercado que gusta de diseños atemporales de alto nivel.*

*Como siempre, detrás de PEROBELL hay un elenco de diseñadores que forjaron la leyenda de un catálogo inolvidable: Pensi, Lievore, Rifé, Codina... los autores de un repertorio de clásicos imbatible que vuelve a equipar los entornos del siglo XXI. Premier, Chocolate, Protos... son nombres que forman parte de la historia del diseño de este país. Que viajaron más allá de nuestras fronteras para seducir a los amantes del interiorismo contemporáneo de todo el mundo.*

*¿Por qué ahora PEROBELL? Porque detrás de una gran marca hay personas. Y circunstancias, dificultades, alegrías... pero, sobre todo, hay un fondo de ilusión depositado en cada pieza con la pequeña etiqueta roja. El orgullo de una forma de entender el diseño que pasa por la calidad productiva y la seriedad del servicio. Vuelve un clásico. PEROBELL vuelve.*

Marcel Benedito



We believe in a new way of producing, slow growing and sustainability as a way to connect with our customers and local suppliers.

<sup>EN</sup> Time is the best ally of a project. Nothing helps more than time to develop an idea, a trajectory, a legacy. Perobell was founded in 1978 and based on know-how and a passion for design, it managed to prosper and evolve. To metamorphose when necessary. To return to the origin when time dictated it. Perobell has known how to adapt to the circumstances, to build a long-term story and to recover his history.

A story in which love for detail, well done and quality have been the roadmap to follow. A history that has always been marked by the search for excellence. This search must continue to continue being what it was, what it is and will be in the future. A synonym of quality and reliability. A company that provides solutions to the habitat from honesty and responsibility with resources and technology without forgetting the tradition that has brought us here.

Perobell does not seek to produce following passing and outdated fashions, but pieces of timeless and eternal beauty, which time knows how to treat well. Products that provide differentiation and practicality to society. Products designed to last, that travel back in time with their owners. We believe in a way to produce and grow slowly and sustainably as a way to connect with our local customers and suppliers. Perobell has a time commitment.

<sup>ES</sup> *El tiempo es el mejor aliado de un proyecto. Nada ayuda más que el tiempo a desarrollar una idea, una trayectoria, un legado. Perobell fue fundada en 1978 y a base saber hacer y pasión por el diseño logró prosperar y evolucionar. A metamorfosearse cuando fue necesario. A volver al origen cuando el tiempo lo dictó. Perobell ha sabido adaptarse a las circunstancias, a construir un relato a largo plazo y a recuperar su historia.*

*Una historia en la que el amor al detalle, a lo bien hecho y la calidad han sido la hoja de ruta a seguir. Una historia que siempre ha estado marcada por la búsqueda de la excelencia. Esa búsqueda debe continuar para seguir siendo lo que fue, lo que es y será en el futuro. Un sinónimo de calidad y fiabilidad. Una empresa que aporte soluciones al habitat desde la honestidad y la responsabilidad con los recursos y la tecnología sin olvidar la tradición que nos ha traído hasta aquí.*

*Perobell no busca producir siguiendo modas pasajeras y caducas, sino piezas de belleza atemporal y eterna, de la que el tiempo sabe tratar bien. Productos que aporten diferenciación y practicidad a la sociedad. Productos concebidos para durar, que viajen en el tiempo con sus dueños. Creemos en una forma de producir y crecer de forma lenta y sostenible como una forma de conectar con nuestros clientes y proveedores locales. Perobell tiene un compromiso con el tiempo.*



# Pensi Design Studio



<sup>EN</sup> The studio was set up in 1984 in Barcelona's Gothic quarter, specialising in furniture and lighting design, the visual image of its products and staging for different types of events. In 2007 the team moved to a new space in Barcelona's Olympic Village, overlooking the sea.

"Our working method is characterised by intensive communication between the team and their clients throughout the design phase, from the initial idea to the final product, in a relaxed and creative environment".

<sup>ES</sup> *El estudio se creó en 1984 en el barrio Gótico de Barcelona, especializándose en el diseño de mobiliario e iluminación, la imagen visual de sus productos y la escenografía de diferentes tipos de eventos. En 2007 el equipo se trasladó a un nuevo espacio en la Villa Olímpica de Barcelona con vistas al mar.*

*"Nuestro método de trabajo se caracteriza por una intensa comunicación entre el equipo y sus clientes durante toda la fase de diseño, desde la idea inicial hasta el producto final, en un ambiente distendido y creativo".*



EN They are specialized in product design & development, strategic consulting, creative direction, art direction, and ephemeral architecture for internationally recognized design companies.

Their approach develops projects using an established strategy: a creative concept integrating product design and its communication. This holistic approach, humanist character, and the search for the essential in their projects combined with a sensibility that transmits harmony and balance.

ES *Están especializados en diseño y desarrollo de productos, consultoría estratégica, dirección creativa, dirección de arte y arquitectura efímera para empresas de diseño reconocidas internacionalmente.*

*Su enfoque desarrolla proyectos utilizando una estrategia establecida: un concepto creativo que integra el diseño del producto y su comunicación. Este enfoque holístico, el carácter humanista y la búsqueda de lo esencial en sus proyectos se combinan con una sensibilidad que transmite armonía y equilibrio.*

# Lluís Codina



EN Lluís Codina's extensive professional background has allowed him to work with leading national and international furniture companies. With multidisciplinary training in different fields of design and new technologies, he began his professional activity more than twenty-five years ago. From communication and graphic design agencies to industrial design and computer graphics, he completes his training and accumulates experience that leads to the creation of projects that define a markedly personal style and character.

ES *El extenso bagaje profesional de Lluís Codina le ha permitido trabajar con empresas de mobiliario de primera línea nacional e internacional. De formación pluridisciplinar en diferentes campos del diseño y las nuevas tecnologías, inicia su actividad profesional hace más de veinticinco años. Desde agencias de comunicación y diseño gráfico hasta diseño industrial e infografía, va completando su formación y acumulando experiencia que desemboca en la creación de proyectos que definen un estilo y un carácter marcadamente personal.*

# Héctor Diego



EN "Formal correctness and proportion as fundamental premises. Projects that seek timelessness as added value, avoiding passing fashions and appreciating detail, both technical and constructive".

He studied Technical Engineering in Industrial Design in Valencia, graduating after a Master in Product Development in 1998, later establishing his own studio in 2001, in which he performs Industrial Design, Art Direction, Exhibition Mounting and Product Presentation tasks.

ES "Corrección formal y proporción como premisas fundamentales. Proyectos que buscan la atemporalidad como valor añadido, evitando modas pasajeras y apreciando el detalle, tanto técnico como constructivo".

*Estudió Ingeniería Técnica en Diseño Industrial en Valencia, graduándose tras un Master en Desarrollo de Producto en 1998, posteriormente estableció su propio estudio en 2001, en el que se realizan tareas de Diseño Industrial, Dirección de Arte, Montajes Expositivos y Presentación de Producto.*

# Francesc Rifé



<sup>EN</sup> Interior and industrial designer, Francesc Rifé (Sant Sadurní d'Anoia, 1969) founded his own studio in Barcelona in 1994. Influenced by minimalism and following a familiar tradition linked to craftsmanship, his work focuses on ways of approaching material honesty, spatial order and geometric proportion.

His work has been widely released in the general press as well as specialized publications and books worldwide. Also, there have been several published books that collect his most outstanding works. Currently, he works as well as leads workshops and conferences.

<sup>ES</sup> *Interiorista y diseñador industrial, Francesc Rifé (Sant Sadurní d'Anoia, 1969) funda su estudio en Barcelona en 1994. Influenciado por el minimalismo, y marcado por una historia familiar ligada a la artesanía, articula toda su obra en torno al orden espacial y a la proporción geométrica. También demuestra una especial atracción por los materiales nobles que no le abandonará jamás.*

*Su trabajo ha sido ampliamente divulgado en prensa generalista así como en publicaciones y libros especializados a nivel nacional e internacional. Asimismo se han editado varios libros que recopilan sus obras más destacadas. Durante años se ha dedicado a la docencia y tiene un papel activo en talleres, congresos y conferencias.*



# Antoni Pallejá



EN They are specialized in product design & development, strategic consulting, creative direction, art direction, and ephemeral architecture for internationally recognized design companies.

Their approach develops projects using an established strategy: a creative concept integrating product design and its communication. This holistic approach, humanist character, and the search for the essential in their projects combined with a sensibility that transmits harmony and balance.

ES *Están especializados en diseño y desarrollo de productos, consultoría estratégica, dirección creativa, dirección de arte y arquitectura efímera para empresas de diseño reconocidas internacionalmente.*

*Su enfoque desarrolla proyectos utilizando una estrategia establecida: un concepto creativo que integra el diseño del producto y su comunicación. Este enfoque holístico, el carácter humanista y la búsqueda de lo esencial en sus proyectos se combinan con una sensibilidad que transmite armonía y equilibrio.*



**COLLECTION**



22	AFRIKA
30	ARAMIS
36	ARMAND
40	ATHOS
48	BUD
56	CHOCOLATE
62	CONTINENTAL
68	FABRA
72	GRAN VÍA
76	LIMA
82	LOFT
92	MONROE
96	OBERON
102	PREMIER
106	PROTOS
116	SAM
126	SAL Y PIMIENTA
132	WALLACE
138	ZONE

# AFRIKA

by Pensi Design Studio

2014 EN Sophistication and pure lines in contrast with the comfort and warmth of the seat are the features that define this Perobell's classic.

ES *Sofisticación y líneas puras en contraste con el confort y calidez que transmite su asiento son los rasgos que mejor definen este clásico del catálogo de Perobell.*







EN The sophisticated steel plate inserted in the frame that surrounds the sides of the sofa, also available as a fix or swivel armchair, turns into the legs that support the whole piece, which are available oven-painted, chrome- or nickel-plated. As a contrast to the sober lines of this element, the seat and backrest modules are extremely cosy.

ES *La sofisticada pletina de acero insertada en el armazón que recorre los laterales de este sofá, también en versión butaca fija o giratoria, se convierte en las patas que lo sostienen que pueden ser pintadas al horno, cromadas o niqueladas. Para contrarrestar la sobriedad lineal de este elemento, los módulos de asiento y respaldo son extremadamente acogedores.*









The sophisticated steel plate inserted in the frame turns into the legs that support the whole piece.

# ARAMIS

by Lluís Codina

- 2012
- EN Aramis is a versatile programme with three different seat widths, exceptional lengths, poufs, chaise longue and corner pieces that allow for the composition of a relationship and relax area to the shape of any space.
- ES *Aramis es un programa versátil con tres anchos de asiento, longitudes excepcionales, poufs, chaise longue y rinconeras que permite componer la zona de relación y descanso a medida de cualquier espacio.*













# ARMAND

by Lluís Codina

2012 EN The expressive frame made of solid wood supports this beautiful and compact armchair that expresses comfort and homely warmth in all types of atmospheres.

ES *La expresiva estructura de madera maciza sostiene esta bella y compacta butaca que expresa confort y calidez de hogar en todo tipo de ambientes.*







# ATHOS

by Lluís Codina

- 2010 EN Line of sofas with an innovative silhouette, without armrests, made up of a series of curves that converge in a beautiful piece with character.
- ES *Línea de sofás de silueta innovadora, sin brazos, compuesta por una serie de curvas que confluyen en una pieza bella y con carácter.*









The backrest and the seat are independent pieces, so that they can be upholstered with different materials to customise them even more.







# BUD

by Francesc Rifé

- 2017 EN Bud is equilibrium and order. Symmetry and correctness. A collection whose design reminds us of Japanese minimalism.
- ES *Bud es equilibrio y orden. Simetría y corrección. Una colección cuyo diseño nos recuerda al minimalismo japonés.*





Bud creates a particular look as fine wood with a clean and tidy upholstered seat, creating a completely special universe of elegance.











# CHOCOLATE

by Pensi Design Studio

1999 EN The lightness and strength of the metal base have a conversation with a sofa of fluffy seats and backrests, the highest expression of comfort.

ES *La ligereza de su estructura y la fuerza de su base de metal conforman un sofá de asientos y respaldos mullidos, la más alta expresión de confort.*









EN A base made of cross-section alsteel tube surrounds the side profile of this aerial and exquisite sofa that looks for comfort above all. The seat and backrest modules, filled with polyurethane foam covered with goose feathers and hollow fibre secure this target. Chocolate sofa is removable upholstery.

ES *Una base con patas de sección de tubo de acero recorre el perfil de los laterales de este sofá aéreo y exquisito que busca el confort, por encima de todo. Los módulos de asiento y respaldo, rellenos de goma de poliuretano recubierta de plumas de oca y fibra hueca aseguran ese objetivo. Chocolate es totalmente desenfundable.*





# CONTINENTAL

by Lievore Altherr

1992 EN Its monolithic aspect, extremely elegant, provides for a piece with great comfort, welcoming and friendly.

ES *Su aspecto monolítico extremadamente elegante vehicula una pieza de gran confort, acogedora y amigable a la vez.*













# FABRA

by Lievore Altherr

1998 EN An armchair with aesthetic reminiscences of a vintage style that surprises due to the beautiful contrast of the light and solid steel structure and the welcoming inclination of the seat and the backrest. Elegant and with a character.

ES *Una butaca con reminiscencias estéticas de estilo vintage que sorprende por el bello contraste entre la liviana y sólida estructura de acero y la acogedora inclinación de asiento y respaldo. Elegante y con carácter.*







# GRAN VÍA

by Héctor Diego

1998 EN An armchair with aesthetic reminiscences of a vintage style that surprises due to the beautiful contrast of the light and solid steel structure and the welcoming inclination of the seat and the backrest. Elegant and with a character.

ES *Una butaca con reminiscencias estéticas de estilo vintage que sorprende por el bello contraste entre la liviana y sólida estructura de acero y la acogedora inclinación de asiento y respaldo. Elegante y con carácter.*









# LIMA

by Pensi Design Studio

2018 EN Lima inspires a delicate balance between maximum comfort and refined, voluptuous shapes that are contained in a subtle architectural box.

ES *Lima inspira un equilibrio delicado entre un confort máximo y unas formas refinadas y voluptuosas que quedan contenidas en una caja arquitectónica sutil.*





EN A flexible mechanism inside the armrests and on the backrest of the sofa allows it to adapt perfectly to your physiognomy, so you can enjoy a soft and relaxing embrace and a well-deserved rest.

ES *Un mecanismo flexible en el interior de los reposabrazos y en el respaldo del sofá favorecen su adaptación perfecta a tu fisionomía, para que puedas disfrutar así de un abrazo mullido y relajante y de un descanso merecido*











# LOFT

by Lluís Codina

2007 EN Collection with endless versatility that looks for the ideal balance between the horizontal lines of the seat and the backrest and the informal arrangement of the cushions.

ES *Colección con una versatilidad sin fin que busca el equilibrio ideal entre las líneas horizontales del asiento y el respaldo y la disposición informal de los cojines.*



Loft is the ideal solution for those who prefer to decide which type of sofa they want to enjoy depending on the moment and the needs.



EN Loft is the ideal solution for those who prefer to decide which type of sofa they want to enjoy depending on the moment and the needs. A wooden structure covered with polyurethane offers the ideal base for a set of cushions filled with goose feathers and hollow fibres that allow to change the seat and to discover its multiple possibilities. This is complemented by a large number of components and sizes, with poufs and corner pieces to provide for more versatility

ES *Loft es la solución ideal para quienes prefieren decidir el tipo de sofá que quieren disfrutar según el momento y las necesidades. Una estructura de madera recubierta de poliuretano ofrece la base idónea para el conjunto de cojines de pluma de oca y fibras huecas que permite metamorfosear el asiento y descubrir sus múltiples personalidades. A ello se une un gran número de componentes y medidas, con pouf y rinconeras para darle mayor versatilidad.*















A large number  
of components  
and sizes allow  
to change the  
composition  
and to discover  
its multiple  
possibilities.

# MONROE

by Lievore Altherr

- 2012
- EN A huge combination potential and a coherent frame that provide it with the ability to give an answer to the most varied requirements.  
The reclining back reminds us that comfort is a personal criterion.
- ES *Un enorme potencial de combinación y un marco coherente que le proporcionan la capacidad de dar respuesta a las más variadas exigencias.  
El respaldo reclinable nos recuerda que la comodidad es un criterio personal.*







Monroe reminds us that comfort is a personal criterion.





# OBERÓN

by Lievore Altherr

- 1998
- EN Oberón has the particularity of providing the sofa with the function of a divan and incorporating a mechanism capable of modifying the inclination of the backrest, making it the perfect solution. The result of the union of beauty, utility and comfort.
- ES *Oberón presenta la particularidad de proporcionar al sofá la función de diván y de incorporar un mecanismo capaz de modificar la inclinación del respaldo, haciendo de él la perfecta solución. Resultado de la unión de belleza, utilidad y confort.*







# PREMIER

by Alberto Lievore

1984 EN This sofa is born out of the combination of design and engineering. Sober, elegant and extraordinarily comfortable, it has turned into an undeniable classic. The internal mechanism of the backrest lets you find your perfect inclination, on a frame of pure lines.

ES *De la comunión entre diseño e ingeniería nace este sofá, sobrio, elegante y extraordinariamente cómodo que ya se ha convertido en un clásico indiscutible. El mecanismo interno del respaldo permite hallar la inclinación exacta al gusto de cada uno sobre una estructura de líneas puras.*









# PROTOS

by Lluís Codina

- 2008 EN Protos is a new formulation of the classic sofa, with a deeper seat, for more informal uses and a significant improvement of comfort.
- ES *Protos es una nueva formulación del sofá clásico, con un asiento más profundo, para usos más informales y una importante mejora del confort.*











Protos is a new formulation of the classic sofa, with a deeper seat, for more informal uses and a significant improvement of comfort.









# The dynamic lines of the beautiful structure empha- sise the feeling of comfort.

<sup>EN</sup> A collection that can be configured with modules of 70, 90 and 120 cm and two different widths for the armrest, 14 and 28 cm, that allow for countless combinations, adaptable to any space.

<sup>ES</sup> *Una colección configurable con módulos de 70, 90 y 120 cm y dos anchos diferentes para el reposabrazos, 14 y 28 cm, que permiten innumerables combinaciones, adaptables a cualquier espacio.*



# SAM

by Francesc Rifé

- 2017
- EN Slender and contemporary, the SAM line is Francesc Rifé's answer to the furniture of the future: more versatile pieces that are suitable for residential, commercial and office use.
- ES *Esbelta y contemporánea, la línea SAM es la respuesta de Francesc Rifé al mobiliario del futuro: piezas más versátiles y adecuadas para uso residencial, comercial y de oficina.*







SAM is Francesc Rife's answer for the furniture of the future: more versatile pieces that are suitable for residential, commercial and office use.













# SAL Y PIMIENTA

by Pensi Design Studio

2011 EN Program of sofas for the home that stands out for its light structure and great comfort. They incorporate cushions of different sizes to adapt to any posture. They come in two different heights: one low and one higher. Both heights can be combined to create particular spaces and atmosphere.

ES *Programa de sofás para el hogar que destaca por su estructura ligera y su gran confort. Incorporan cojines de diferentes tamaños para adaptarse a cualquier postura. Se presentan en dos alturas diferentes: una baja y otra más alta. Ambas alturas pueden combinarse entre sí para crear espacios y ambientes particulares.*













# WALLACE

by Antoni Pallejá

2014 EN The comfortable elegance of this collection proposes an adaptable use of the armrests. A sofa that changes its mood according to the mood of whoever is using it.

ES *La cómoda elegancia de esta colección invita a un uso adaptable de los apoyabrazos. Un sofá que cambia su carácter según el estado de ánimo de quien lo usa.*





EN The Wallace collection consists of a sofa, available in several sizes, and an armchair, with configurable armrests that facilitate different uses, more or less formal, according to the moment. The frames are made of reinforced flanders pine wood, suspension by means of high-quality belts and filling made of polyurethane foam with different densities, covered by a duvet filled with goose feathers and micro fibres

ES *La colección Wallace se compone de sofá en varias medidas y butaca, con brazos configurables que facilitan diversos usos, más o menos formales, según el momento. Está realizada con estructuras de madera de pino Flandes reforzada, suspensión mediante cinchas de alta calidad y relleno de espuma de poliuretano con varias densidades, cubierto por edredón de plumas de oca y microfibras.*









# ZONE

by Héctor Diego

2010 EN The feeling of surrounding comfort of this arm-chair seems to be contradicting the straight and conclusive lines of its profile. Zone, with its double inclination in the base, made of square steel tube and solid rod, both chrome-plated, has been made to surprise.

ES *La sensación de envolvente comodidad de esta butaca parece entrar en contradicción con las líneas rectas y tajantes de su perfil. Zone, con su doble inclinación de la base, de tubo cuadrado de acero y varilla maciza, ambas cromadas, está pensada para sorprender.*









**TECHNICAL INFO**  
***INFORMACIÓN TÉCNICA***

# AFRIKA

EN Frame made of reinforced flanders pine wood; seat suspension by means of high-quality elastic belts. Solid metal legs; available finishes: nickel chrome matt or shiny finish, as well as customised RAL varnish (with surcharge). Cushions made of CFC-free polyurethane foam core, covered by a duvet filled with goose feathers. Fixed upholstery for the frame and removable for the cushions. Possibility to combine frame and cushion fabrics.

ES Estructura de madera de pino flandes reforzada; suspensión mediante cinchas elásticas de alta calidad en asiento. Pies metálicos macizos; acabados disponibles: tratamiento níquel/ cromo mate o brillo, así como lacado en RAL cliente (con cargo adicional). Cojines compuestos por alma de espuma de poliuretano libre de CFC y envueltos por edredón de plumas de oca. Estructura tapizada fija y cojines desenfundables. Posibilidad de combinar tapizados en estructura y cojines.

## Swivel armchair BG

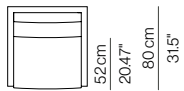
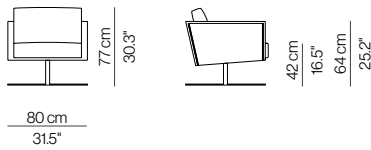

## Armchair B1

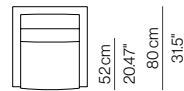
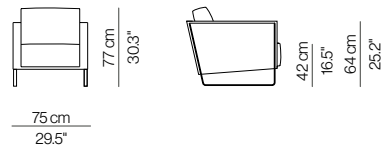

## Armchair B2

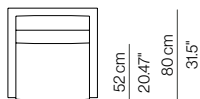
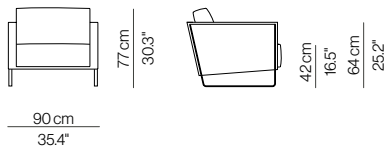

## Low seat LWS

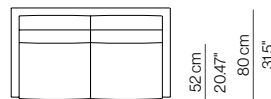
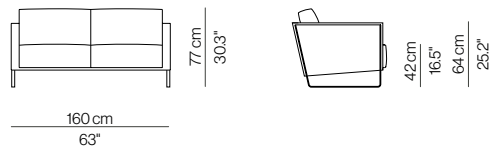

## Two seats sofa S2/P

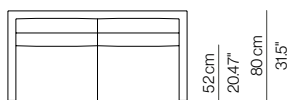
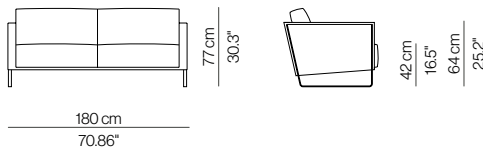

## Three seats sofa S3/P

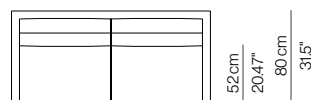
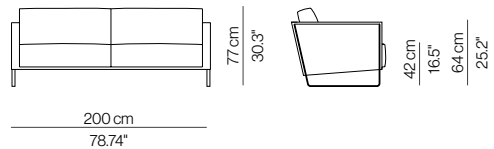



### Four seats sofa S4/P

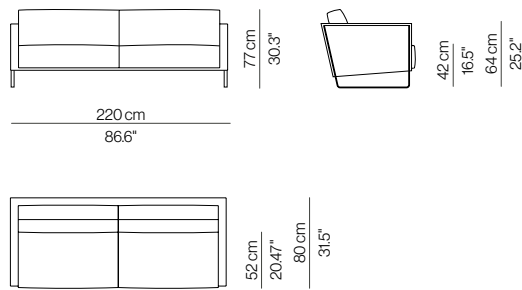

### Four XL seats sofa S4/PXL

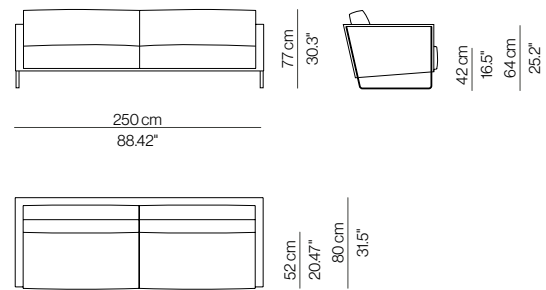

## ARAMIS

EN Base made of reinforced flanders pine wood; internal structures of seat, armrest and backrest made of solid metal rod with anticorrosion protection; suspension by means of high-quality elastic bands. Monoblock seat, backrest and armrest, with a CFC-free polyurethane foam core, with different densities; covered by a duvet filled with goose feathers. Easily detachable elements. Completely removable upholstery, except leather.

ES Base de madera de pino flandes reforzada; estructuras internas de asiento, brazo y respaldos de varilla metálica maciza con tratamiento anticorrosión; suspensión mediante cinchas elásticas de gran calidad. Asientos, respaldos y brazos fabricados en monobloque, con alma de espuma de poliuretano de varias densidades y libre de CFC; todos ellos envueltos por edredón de plumas de oca. Elementos desmontables con gran facilidad. Totalmente desenfundable, excepto piel.

### Armchair B2

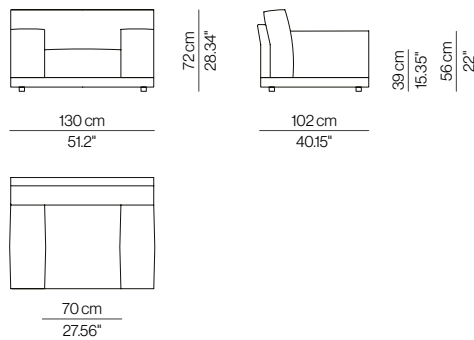

### Corner RI1/P

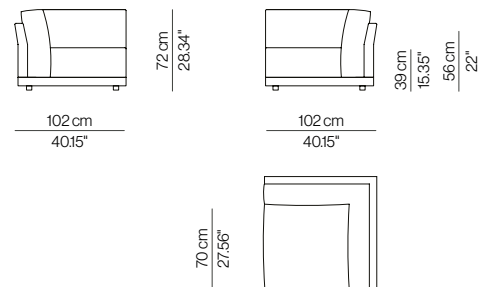

### Chaise longue CHL2

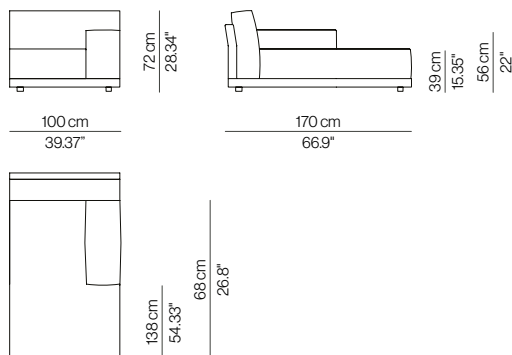

### Chaise longue CHL3

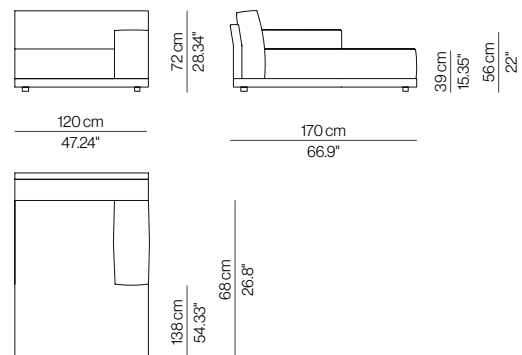

### Central element MD1

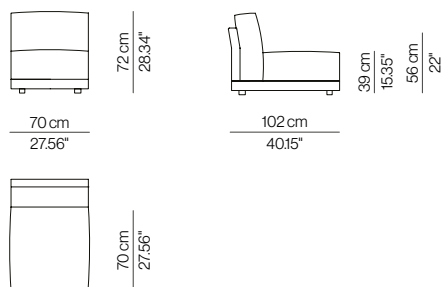

### Pouf PF90

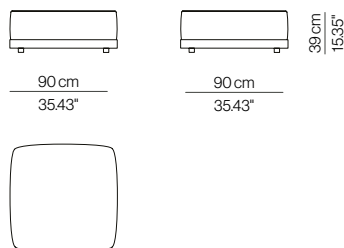

### Central element MD2

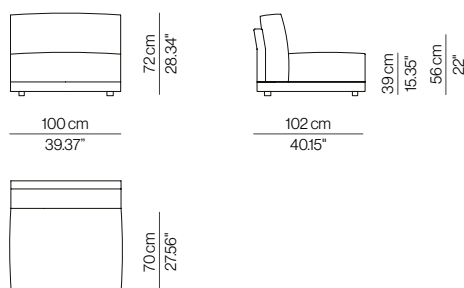

### Lateral element MDB2

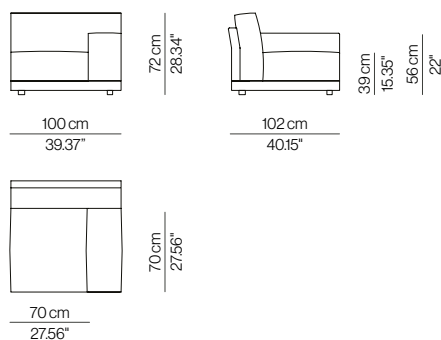

### Central element MD3

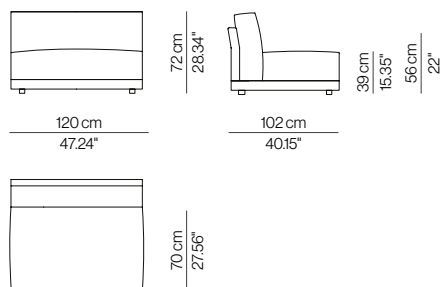

### Lateral element MDB3

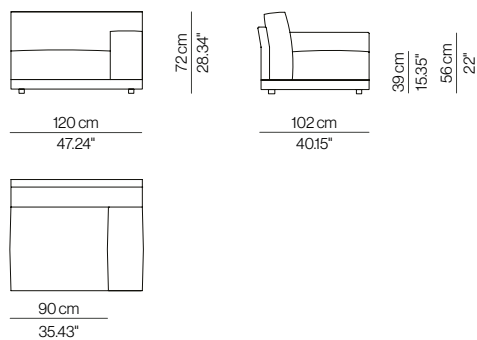

## ARMAND

EN Solid wood frame in American walnut or beech; water-based varnish with natural finish. Mono-block seat and back, made of high-quality CFC-free polyurethane foams, covered by high-quality boata. Non-removable upholstery.

ES Estructura de madera maciza de nogal americano o haya; barnizado al agua con acabado natural. Asiento y respaldo mono - bloque, fabricados con espumas de poliuretano de alta calidad y libres de CFC, recubiertos por boata de alta calidad. Tapizado fijo.

### Armchair B1

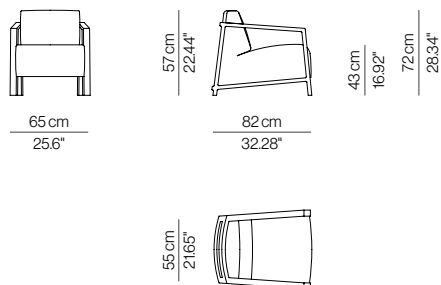

EN Frame made of reinforced flanders pine wood; seat suspension by means of high-quality elastic belts. Monoblock seat and backrest made of CFC-free polyurethane foam, with different densities, covered by high-quality cotton. Possibility to have different fabric for the seat and the backrest. Non-removable upholstery.

ES Estructura de madera de pino flandes reforzada; suspensión de asiento mediante cinchas elásticas de alta calidad. Asiento y respaldo mono - bloque, fabricado en espuma de poliuretano de varias densidades y libre de CFC, recubierto por boata de alta calidad. Posibilidad de tapizado distinto entre asiento y respaldo. Tapizado fijo.

**Two seater sofa S2/P**

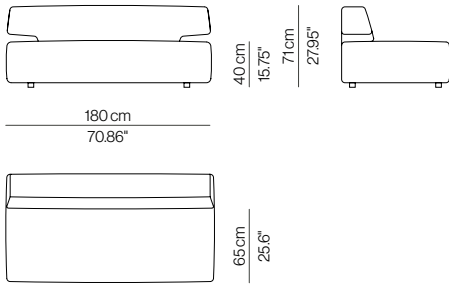

**Three seater sofa S3/P**

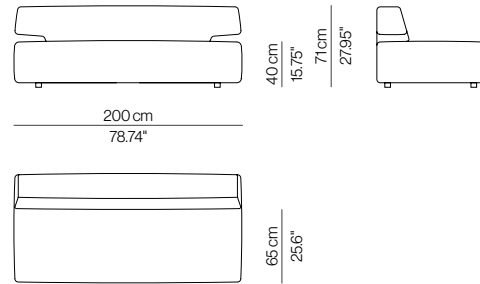

**Four seater sofa S4/P**

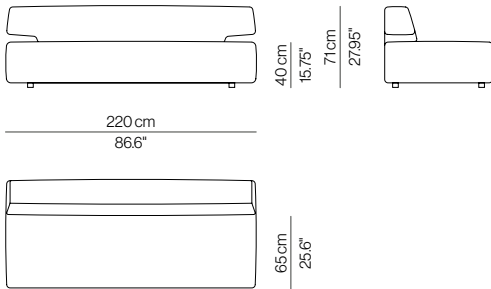

**XL four seater sofa S4/P**

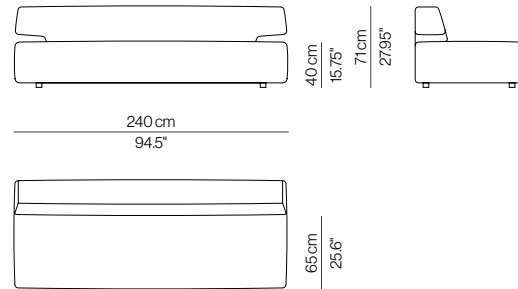

**Pouf PF80**

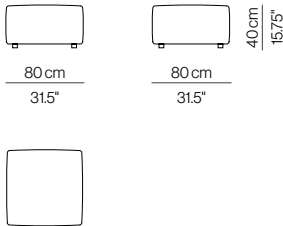

**Pouf PF160**

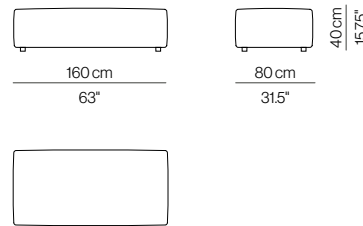

EN Solid American walnut, oak or beech wood structure. Seats, arms and backs made with CFC-free foam. Lumber cushion made of goose feathers. Non-removable upholstery. Consult available wood finishes.

ES Estructura de madera maciza disponible en nogal americano, roble o haya. Asientos, brazos y respaldos compuestos por espumas libres de CFC. Cojín riñonera compuesto por plumas de oca. Tapizado fijo. Consultar acabado de maderas disponible.

**Armchair B1**

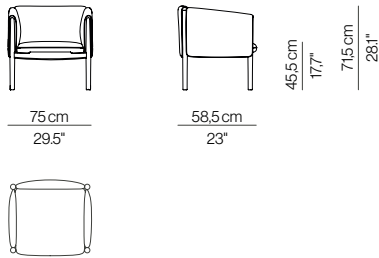

**Bench BR60**

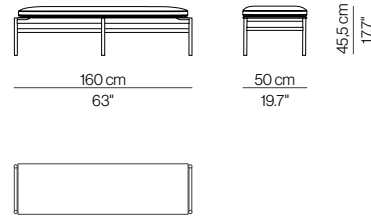

**Table BUDTD60**

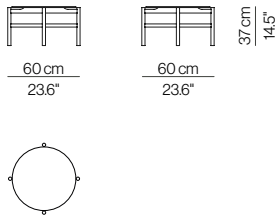

**Table BUDTR160**

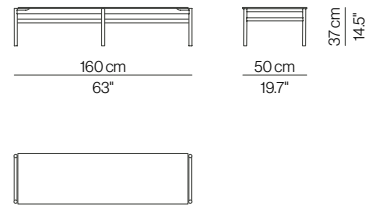

**Table BUDTR100**

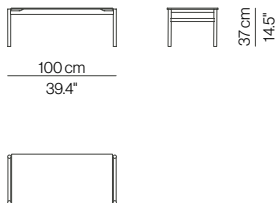

**Table BUDTR54**

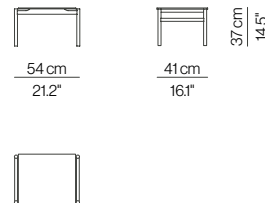

# CHOCOLATE

EN Base made of cross-section alsteel tube. Seat and backrest modules, filled with polyurethane foam covered with goose feathers and hollow fibre. Removable upholstery.

*Base con patas de sección de tubo de acero.*

ES *Módulos de asiento y respaldo, rellenos de goma de poliuretano recubierta de plumas de oca y fibra hueca. Totalmente desenfundable.*

## Armchair B1

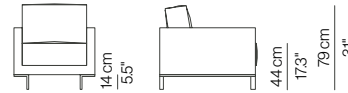
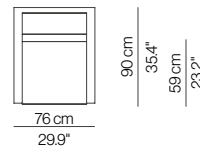

## Armchair B2

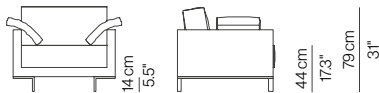
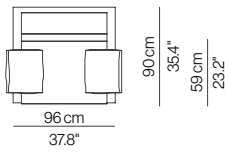

## Low Seat LWS

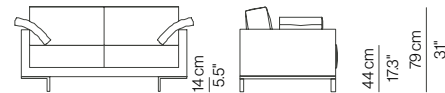
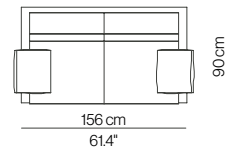

## Two Seater Sofa S2P

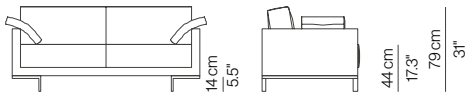
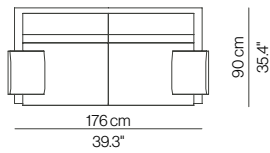

## Three Seater Sofa S3P

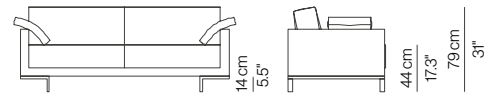
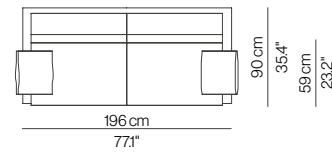

## Four Seater Sofa S4P

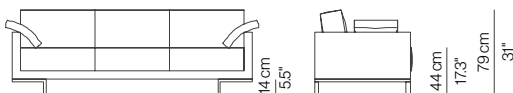
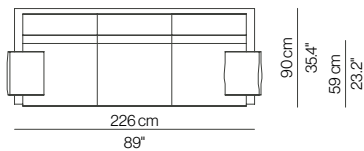

## Four Seater Sofa XL S4PXL

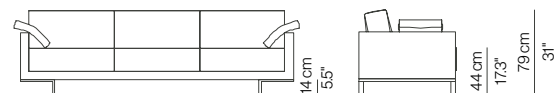
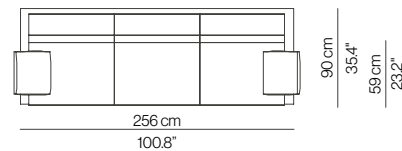

### Table MEC1

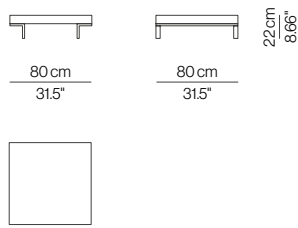

### Table MEC2

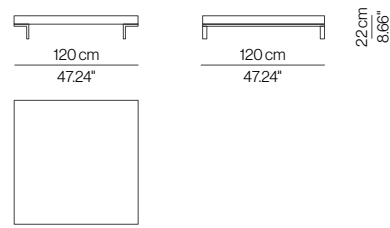

### Table MECR1

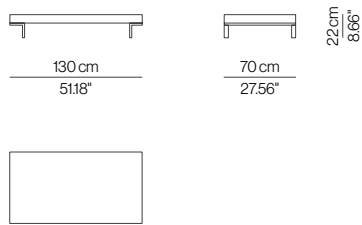

### Table MECR2

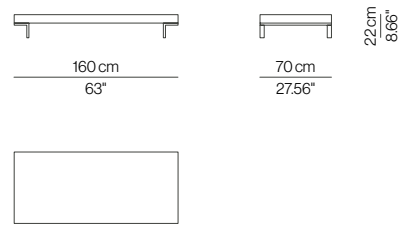

### Pouf PF86

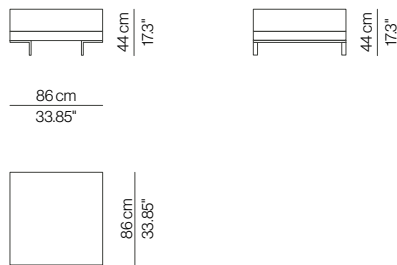

## FABRA

EN Frame made of reinforced flanders pine wood; suspension by means of high-quality elastic belts. Legs made of calibrated tube, coneshaped. Monoblock seat and backrest made of CFC-free polyurethane foam, with different densities, covered by high-quality cotton. Non-removable upholstery

ES *Estructura de madera de pino flandes reforzada; suspensión mediante cinchas elásticas de alta calidad. Pies realizados en tubos calibrados, conificados. Asiento y respaldo fabricados en monobloque con espumas de poliuretano de varias densidades y libres de CFC, recubiertas por boata de alta calidad. Tapizado fijo.*

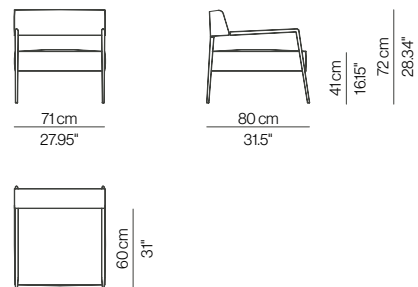

## CONTINENTAL

EN Frame made of reinforced flanders pine wood; seat suspension by means of high-quality elastic belts. Solid metal legs; available finishes: nickel/chrome matt or shiny finish, as well as customised RAL varnish (with surcharge). Cushions made of CFC-free polyurethane foam core, covered by a duvet filled with goose feathers. Backrest made of goose feathers. Removable upholstery, except leather.

ES Estructura de madera de pino flandes reforzada; suspensión mediante cinchas elásticas de alta calidad. Pie perimetral fabricado en tubo calibrado con acabado en tratamiento níquel/ cromo brillo. Asiento compuesto por alma de espuma de poliuretano y libre de CFC, envuelta por edredón de plumas de oca y micro fibras. Respaldo fabricado con plumas de oca. Tapizado desenfundable, excepto piel.

### Armchair B1

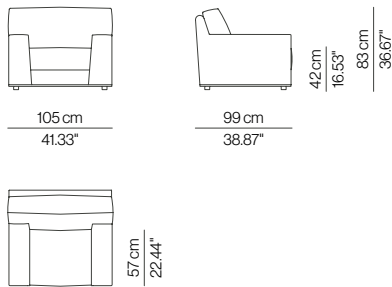

### Two Seater Sofa S2P

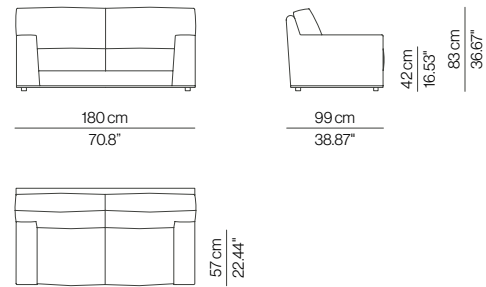

### Three Seater Sofa S3P

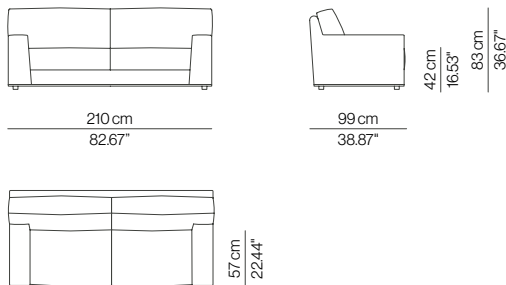

### Four Seater Sofa S4P

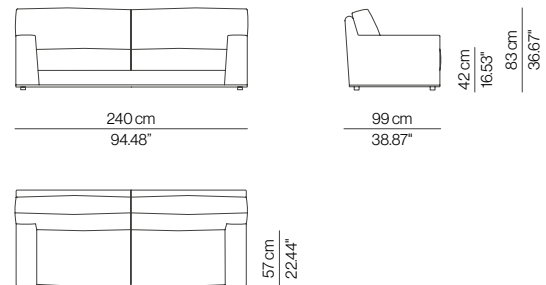

### Four Seater Sofa XL S4PXL

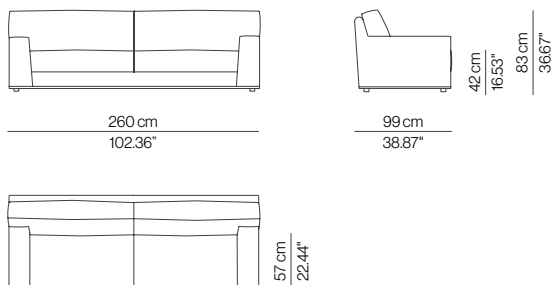

### Pouf 93 cm PF93

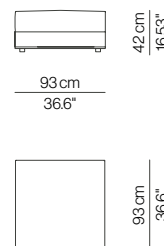

### Pouf 120 cm PF120

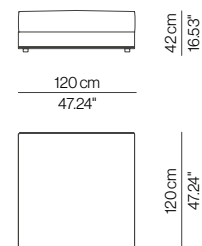

# GRAN VIA

EN Frame made of reinforced flanders pine wood; suspension by means of high-quality elastic belts. Seat made of a CFC-free polyurethane foam core, with different densities, covered by a duvet filled with goose feathers and micro fibres. Backrest and auxiliary cushions made of goose feathers. Completely removable upholstery, except leather.

ES Estructura de madera de pino flandes reforzada; suspensión mediante cinchas elásticas de alta calidad. Asiento elaborado a partir de alma de espuma de poliuretano de varias densidades y libre de CFC, cubierto por edredón de plumas de oca y micro fibras. Respaldo y cojines auxiliares elaborados en plumas de oca. Totalmente desenfundable, excepto piel.

## Armchair B1

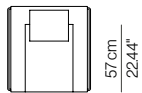
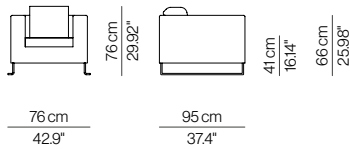

## Two Seater Sofa S2P

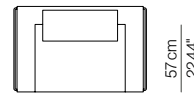
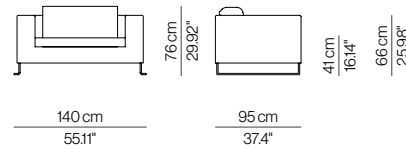

## Three Seater Sofa S3P

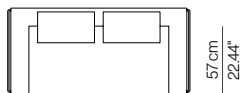
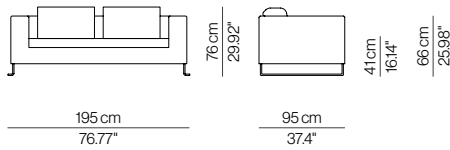

## Four Seater Sofa S4P

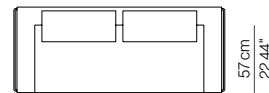
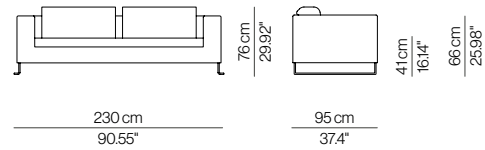

## Three Seater Sofa S3P

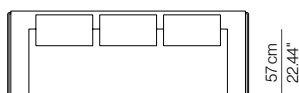
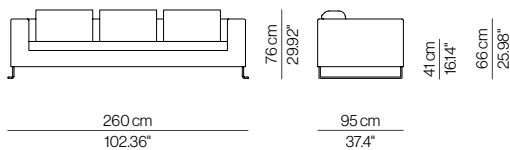

## Pouf PF95

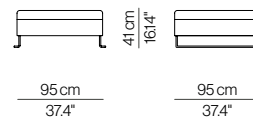

## Table MECC1

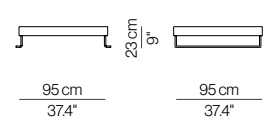



EN Frame made of reinforced flanders pine wood; suspension by means of high-quality elastic belts. Seat made of a CFC-free polyurethane foam core, with different densities, covered by a duvet filled with goose feathers and micro fibres. Backrest and auxiliary cushions made of goose feathers. Completely removable upholstery, except leather.

ES Estructura de madera de pino flandes reforzada; suspensión mediante cinchas elásticas de alta calidad. Asiento elaborado a partir de alma de espuma de poliuretano de varias densidades y libre de CFC, cubierto por edredón de plumas de oca y micro fibras. Respaldo y cojines auxiliares elaborados en plumas de oca. Totalmente desenfundable, excepto piel.

**Armchair B1**

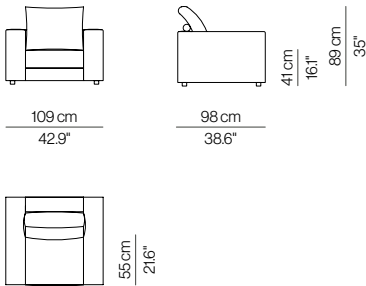

**Two Seater Sofa S2P**

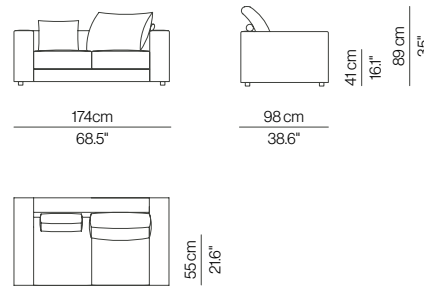

**Three Seater Sofa S3P**

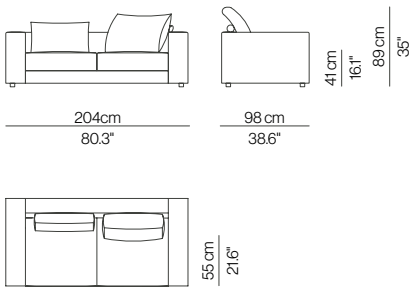

**Four Seater Sofa S4P**

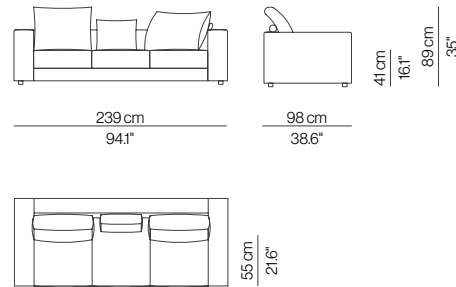

**Four Seater Sofa XL S4PXL**

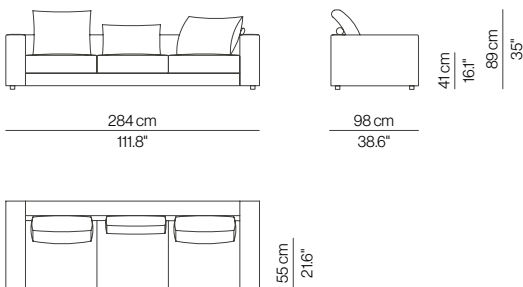

**Lateral Element MDB1**

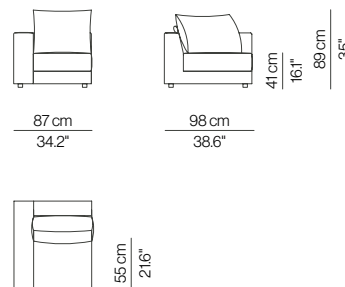

### Lateral Element MDB2

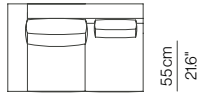
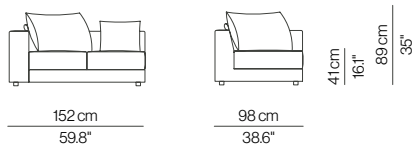

### Lateral Element MDB3

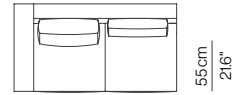
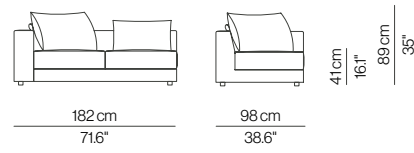

### Lateral Element MDB4

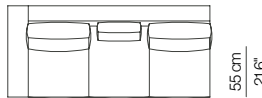
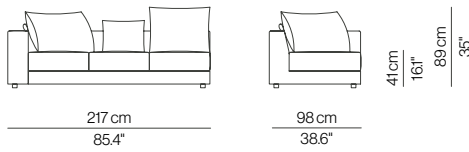

### Lateral Element MDB4XL

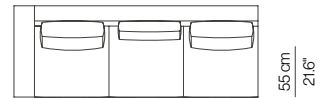
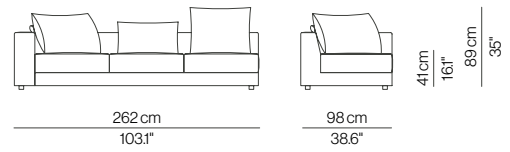

### Corner RI1

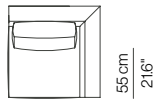
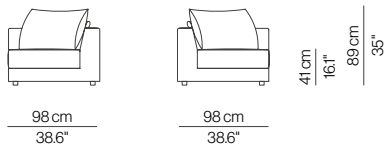

### Central Element MD1

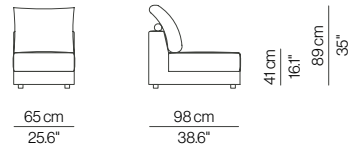

### Central Element MD2

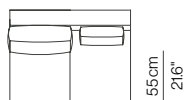
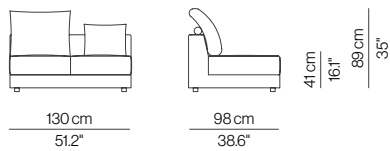

### Central Element MD4

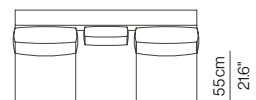
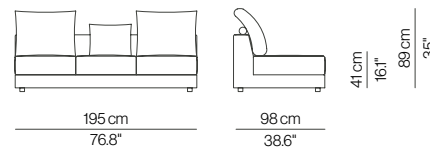

### Central Element MD3

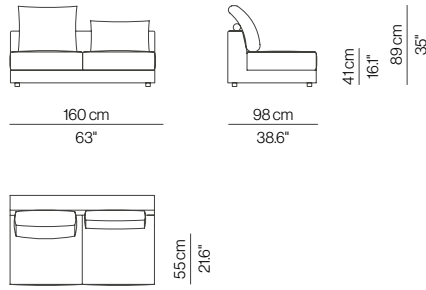

### Central Element MD4XL

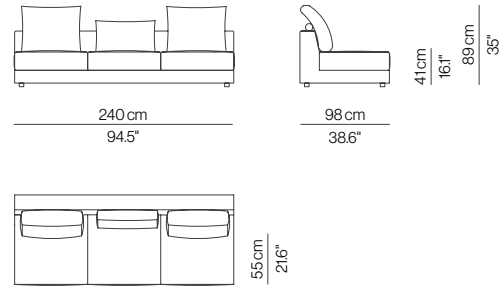

### Chaise Lougue CHL1

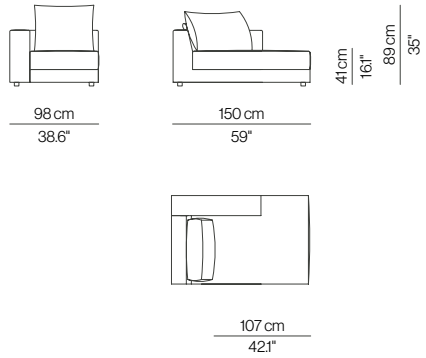

### Chaise Lougue CHL2

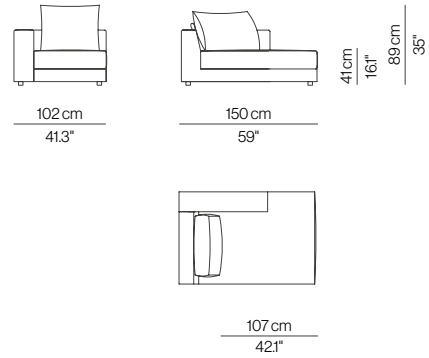

### Central Pouf IS65

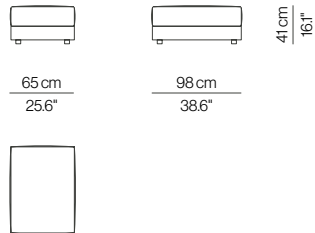

### Central Pouf IS80

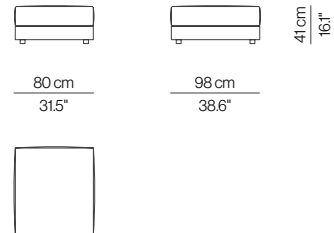

### Pouf PF135

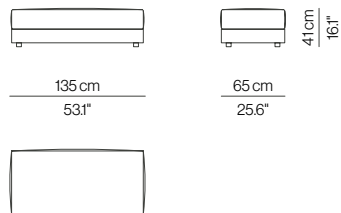

### Pouf PF80

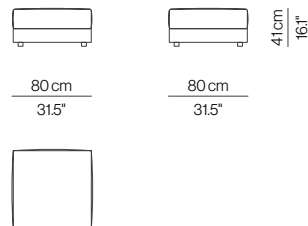

### Pouf PF65

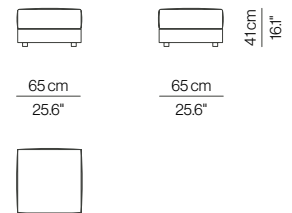

# LIMA

EN Reinforced Flanders pine wood structure; top quality elastic chair webbing. Solid beech wood cylindrical legs. 90° hinge system on the backs and arms. CFC-free foam structure that comes in different thicknesses and it is covered with a goose feather quilt. Removable upholstery.

ES Estructura de madera de pino Flandes reforzada; suspensión mediante cinchas elásticas de alta calidad. Pies cilíndricos de madera maciza de haya. Sistema de articulación 90° en respaldos y brazos. Cojines compuestos por alma de espumas de distintas densidades y libre de CFC y envuelto por edredón de plumas de oca. Totalmente desenfundable.

## Armchair B1

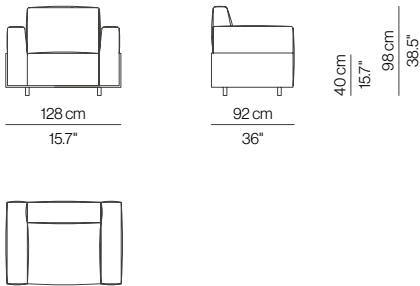

## Two Seater Sofa S2P

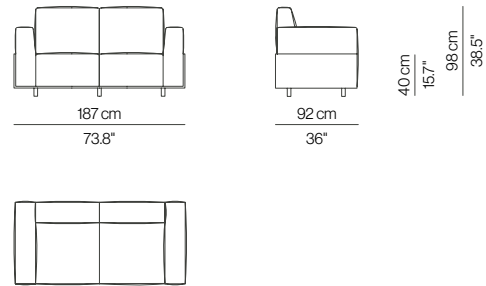

## Three Seater Sofa S3P

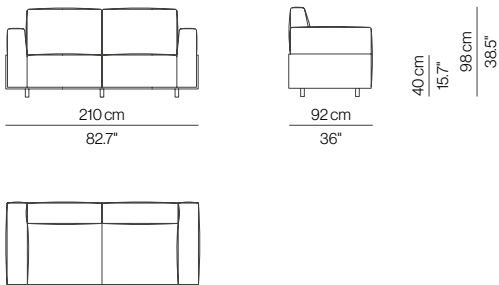

## Four Seater Sofa S4P

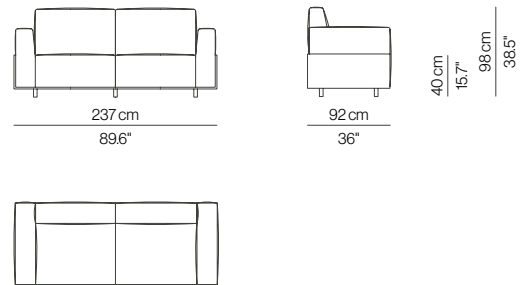

## Four Seater Sofa XL S4PXL

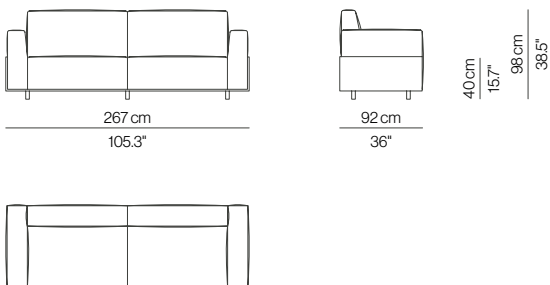

# MONROE

EN Frame made of reinforced flanders pine wood; suspension by means of high-quality elastic belts. Metal legs; available finishes: nickel/chrome shiny or matt finish, as well as customised RAL varnish (with surcharge). Seat and backrest made of a CFC-free polyurethane foam core, with different densities, covered by a duvet filled with goose feathers and micro fibres. Arm cushions made of goose feathers. Removable upholstery, except leather.

ES Estructura de madera de pino flandes reforzada; suspensión mediante cinchas elásticas de alta calidad. Pies metálicos; acabados disponibles níquel/cromo brillo o mate, y lacado en RAL cliente (con cargo adicional). Asientos y respaldos compuestos por alma de espuma de poliuretano de varias densidades y libre de CFC, envueltos por edredón de plumas de oca y micro fibras. Cojines de brazo de plumas de oca. Tapizado desenfundable, excepto piel.

## Armchair B1

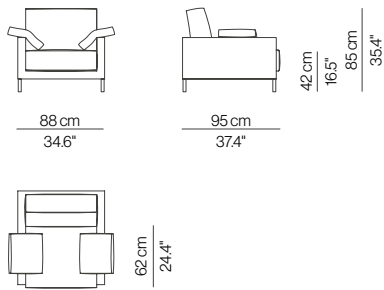

## Armchair B2

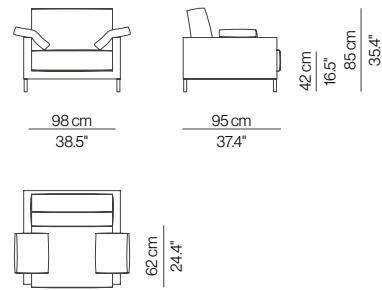

## Low Seat LWS

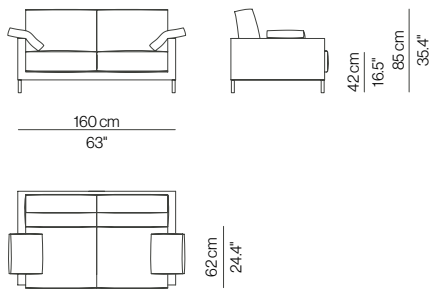

## Two Seater Sofa S2P

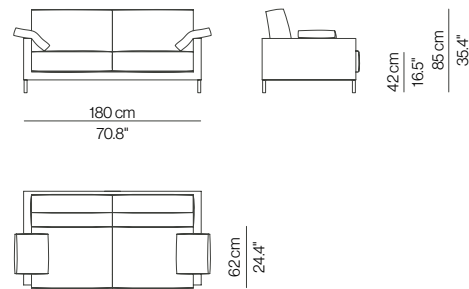

## Three Seater Sofa S3P

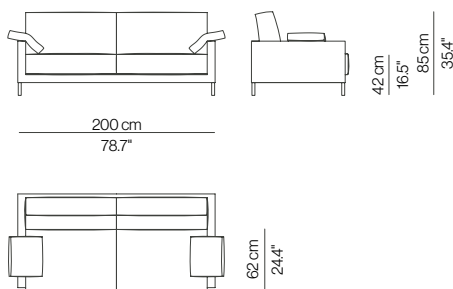

## Four Seater Sofa S4P

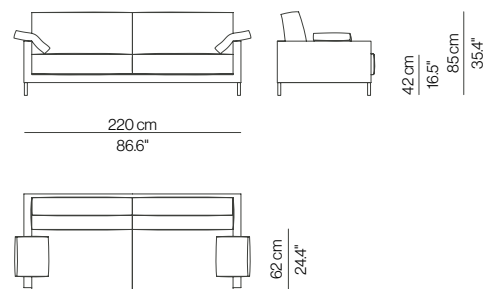

**Four Seater Sofa XL S4PX1**

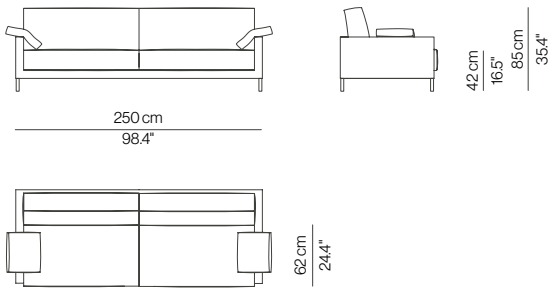

**Pouf PF100**

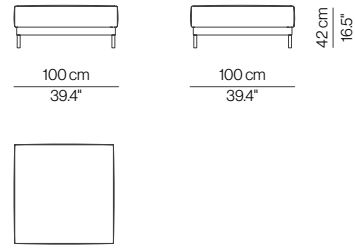

**Lateral Element MD1**

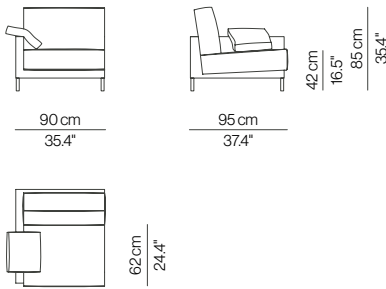

**Low Seat MDBLWS**

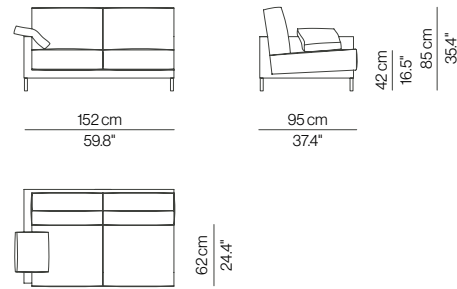

**Two Seater Lateral Elem. MDB2**

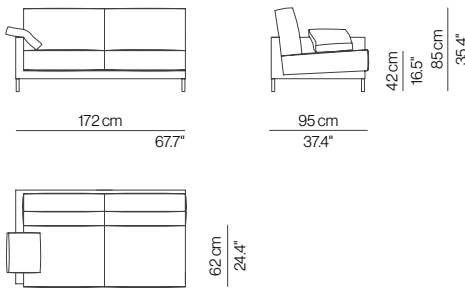

**Three Seater Lateral Elem. MDB3**

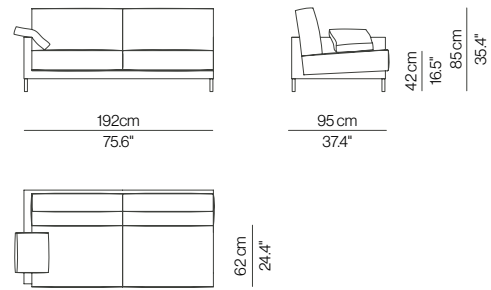

**Four Seater Lateral Elem. MDB4**

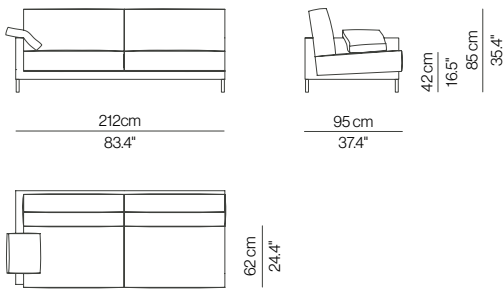

**Four Seater Lateral XL MDB4XL**

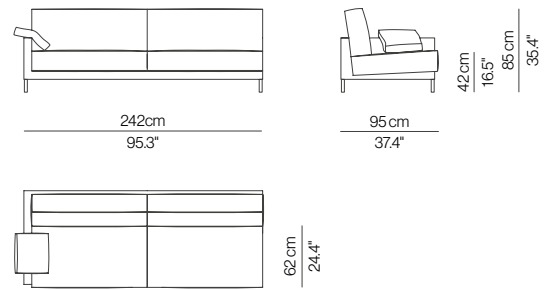

### Central Element MD1

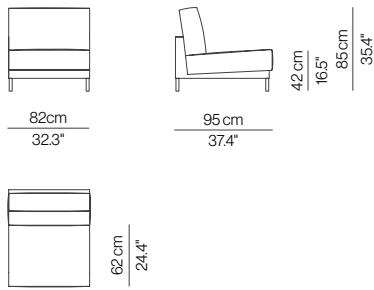

### Low Seat Central Elem. MDLWS

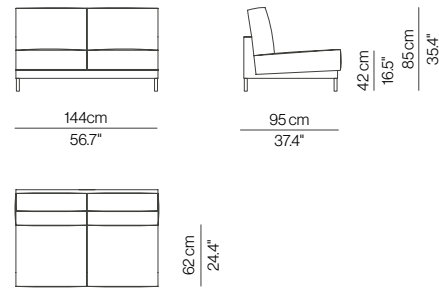

### Two Seater Central Elem. MD2

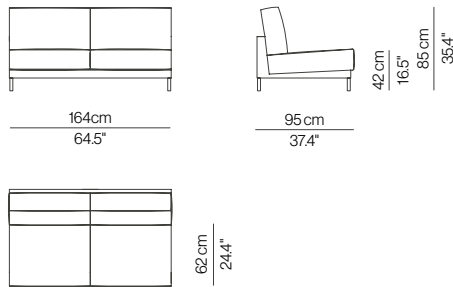

### Three Seater Central Elem. MD3

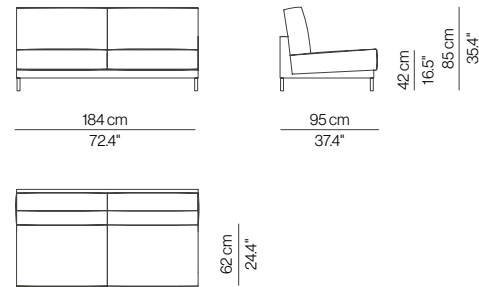

### Four Seater Central Elem. MD4

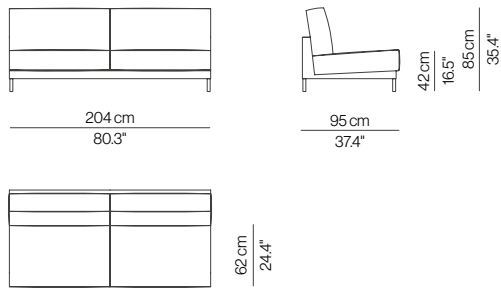

### Four Seater Central XL MD4XL

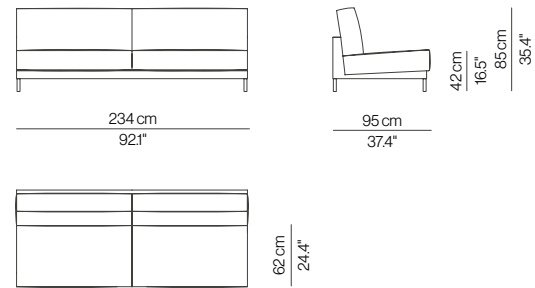

### Corner Element RI

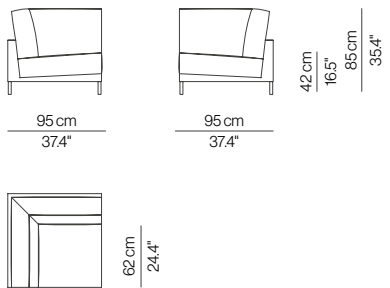

### Chaise Longue 90 CHL2

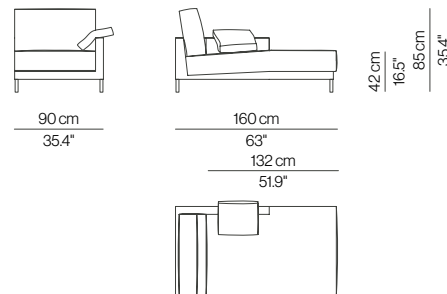

### Chaise Longue 100 CHL3

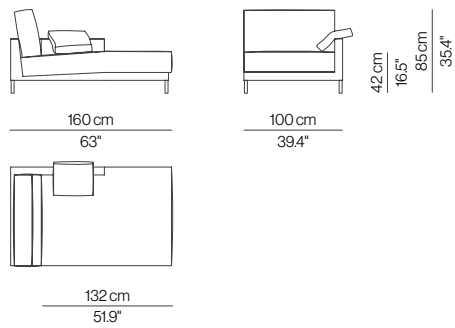

### Chaise Longue 120 CHL4

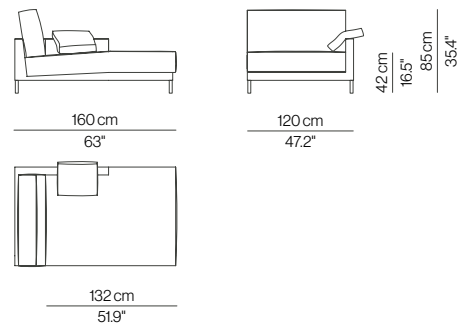

### Lowe Seat / L LWS-L

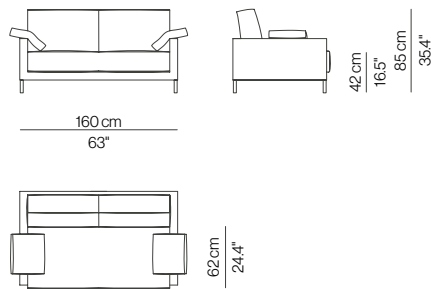

### Two Seater Sofa / L S2P-L

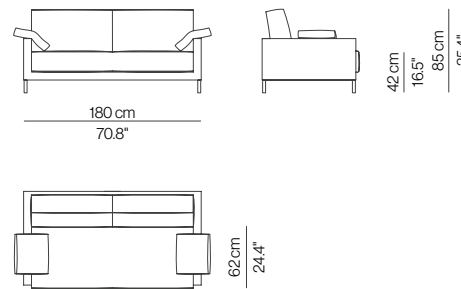

### Three Seater Sofa / L S3P-L

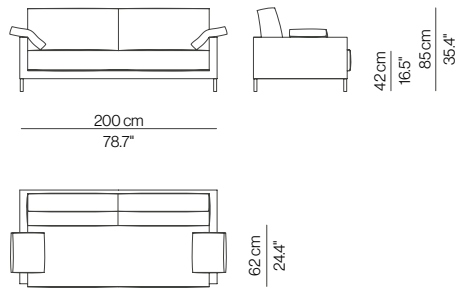

### Four Seater Sofa / L S4P-L

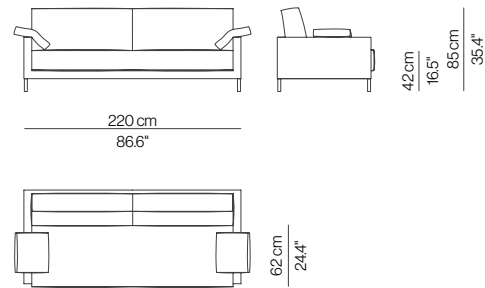

### Four Seater Sofa XL / L S4PXL-L

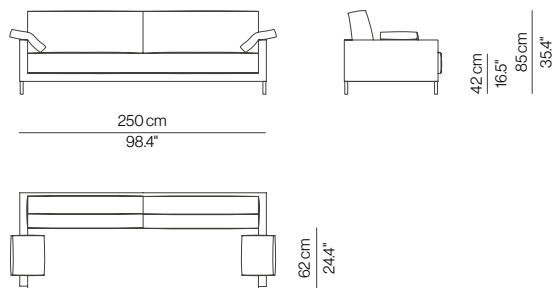

### Cushions CJAUX

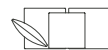



EN Frame made of reinforced flanders pine wood; suspension by means of high-quality elastic belts. Legs made of solid beech wood; available finishes: natural, wenge, cherry, nut and oak. Seat made of a CFCfree polyurethane foam core, with different densities, covered by a duvet filled with goose feathers. Backrest and armrests made of goose feathers. The reclining version has a back-regulation mechanism made in Germany, with 5 positions. Completely removable upholstery, except leather.

ES Estructura de madera de pino flandes reforzada; suspensión mediante cinchas elásticas de gran calidad. Pies de madera maciza de haya; acabados disponibles: natural, wengué, cerezo, nogal y roble. Asiento fabricado con alma de espuma de poliuretano de varias densidades y libre de CFC, envuelto por edredón de plumas de oca. Respaldos y brazos realizados en plumas de oca. En versión reclinable, mecanismo de articulación de respaldo made in Germany, de 5 posiciones. Totalmente desenfundable, excepto piel.

**Armchair B1**

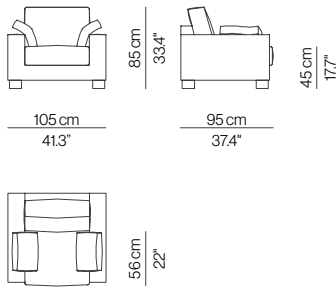

**Pouf PF100**

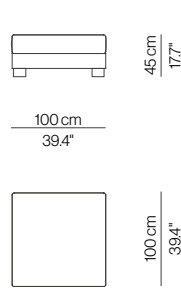

**Two Seater Sofa S2P**

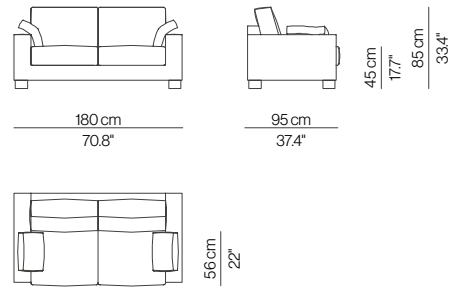

**Three Seater Sofa S3P**

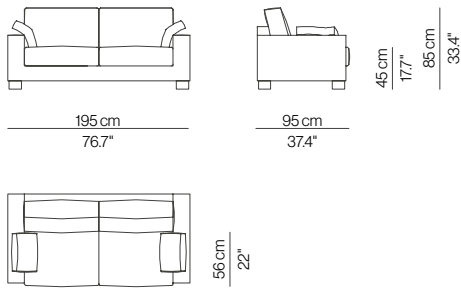

**Four Seater Sofa S4P**

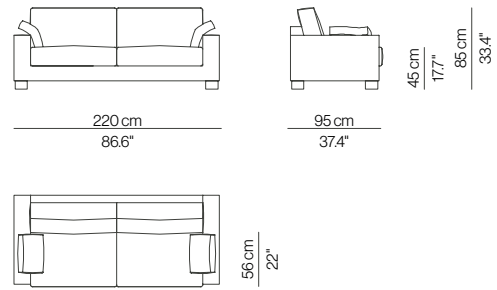

**Four Seater Sofa XL S4PXL**

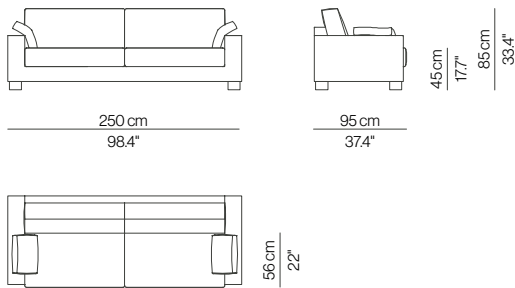

**Chaise Longue CHL2**

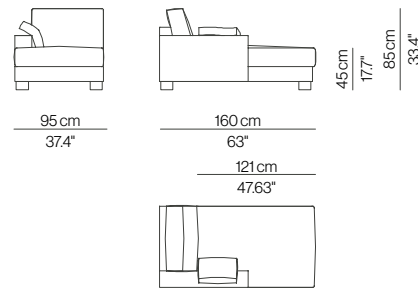

**Armchair High Back B2A**

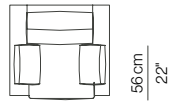
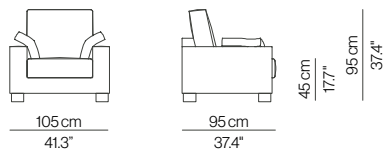

**High Back Two Seater Sofa S2PA**

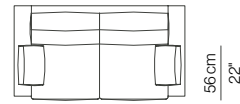
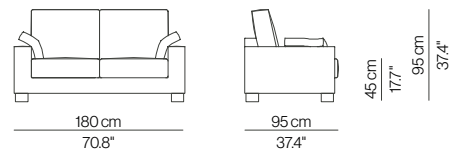

**High Back Three Seater Sofa S3PA**

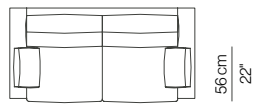
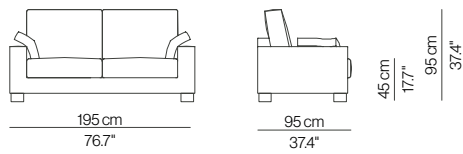

**High Back Four Seater Sofa S4PA**

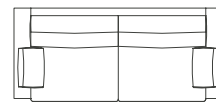
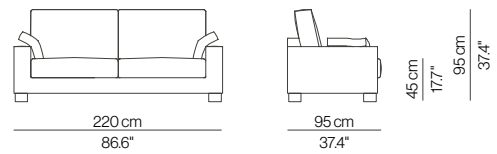

**High Back Four Seater Sofa XLS4PA**

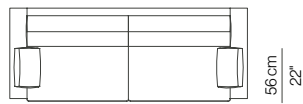
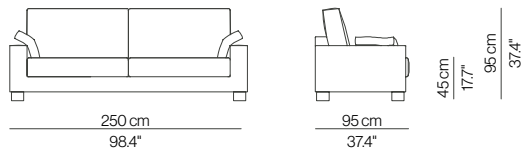

**High Back Chaise Longue CHL2A**

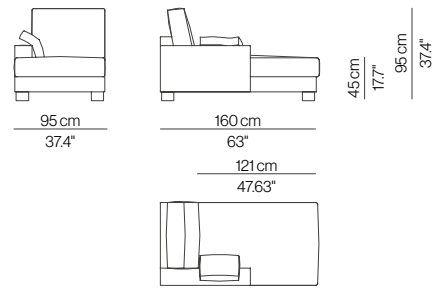

EN Frame made of reinforced flanders pine wood; suspension by means of high-quality elastic belts. Calibrated metal tube or solid beech wood legs; metal finishes: nickel/chrome shiny or matt finish, as well as customised RAL varnish (with surcharge); wood finishes: natural, wenge, cherry, nut and oak. Seat and backrest made of CFC-free high-quality polyurethane foam, covered by high-quality cotton. Completely removable upholstery, except leather.

ES Estructura de madera de pino flandes reforzada; suspensión mediante cinchas elásticas de gran calidad. Pies de madera maciza de haya acabado wengué. Asiento fabricado con alma de espuma de poliuretano de varias densidades y libre de CFC, envuelta por edredón de plumas de oca. Respaldos y brazos realizados en plumas de oca. Mecanismo de articulación de respaldo made in Germany, de 5 posiciones. Tapizado de estructura fijo, cojines desenfundables.

**Armchair B1**

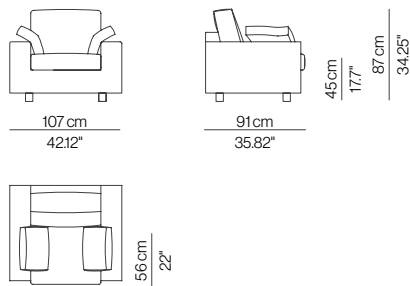

**Low seat LWS**

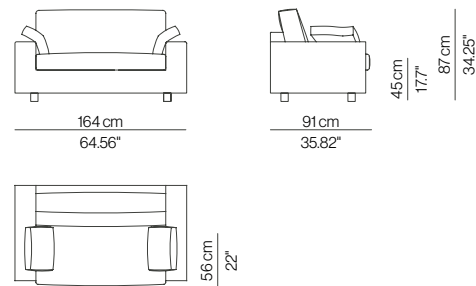

**Two Seater Sofa S2P**

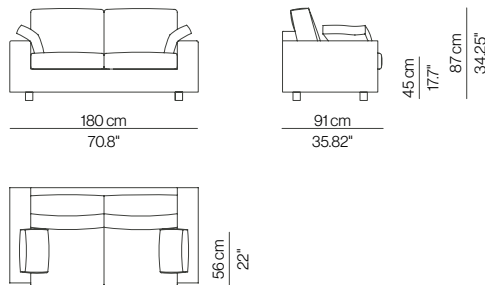

**Three Seater Sofa S3P**

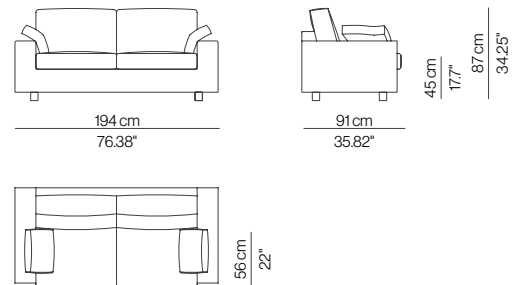

**Four Seater Sofa S4P**

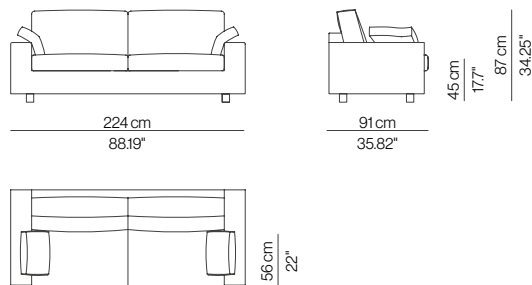

**Chaise longue CHL2**

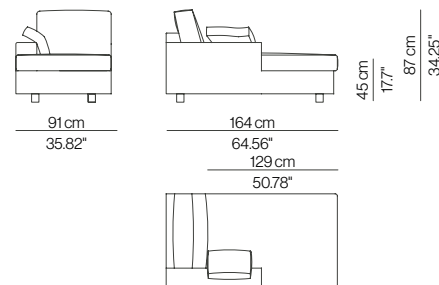

### Central element MD1

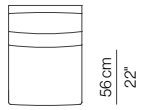
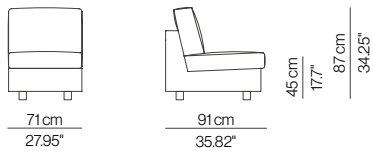

### Lateral element MDB1

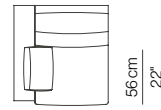
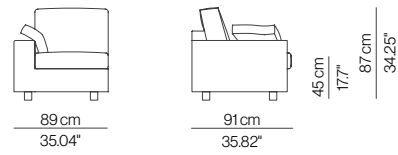

### Central element MD2

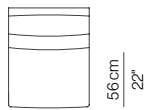
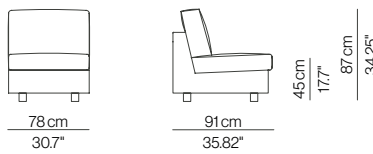

### Lateral element MDB2

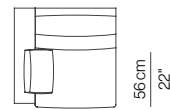
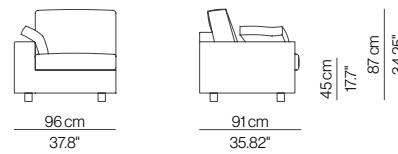

### Central element MD3

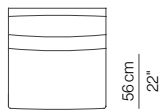
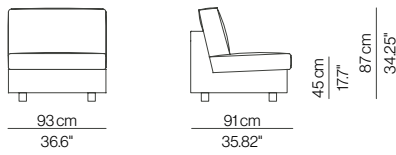

### Lateral element MDB3

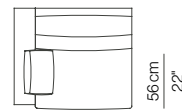
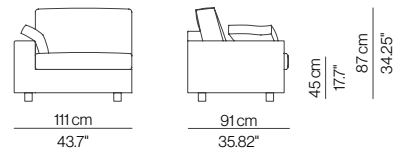

### Corner element RI1P

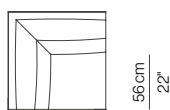
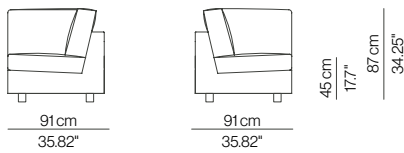

### Pouf PF60

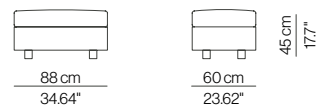

EN Frame made of reinforced flanders pine wood; modular design which allows for large compositions. Monoblock seat with suspension by means of high-quality elastic belts, CFC-free polyurethane foam and duvet filled with goose feathers and micro fibres. Backrest and auxiliary cushions made of goose feathers. Completely removable upholstery, except leather.

ES Estructura de madera de pino flandes reforzada; construcción por módulos que facilita el montaje de grandes composiciones. Asiento monobloque con suspensión de cinchas elásticas de gran calidad, espuma de poliuretano libre de CFC y edredón de plumas de oca y micro fibras. Respaldo y cojines auxiliares fabricados en plumas de oca. Tapizado totalmente desenfundable, excepto piel.

**Armchair B2**

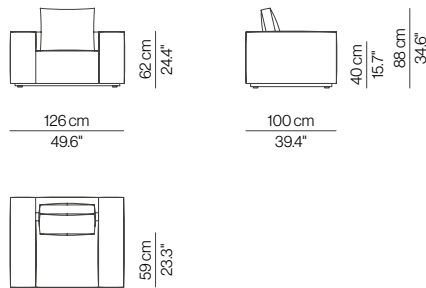

**Two Seater Sofa S2P**

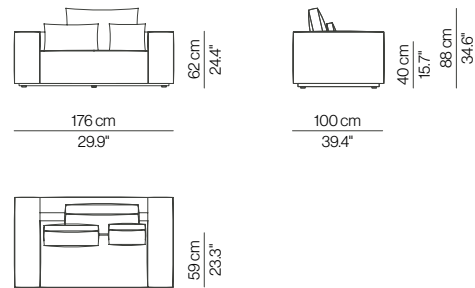

**Three Seater Sofa S3P**

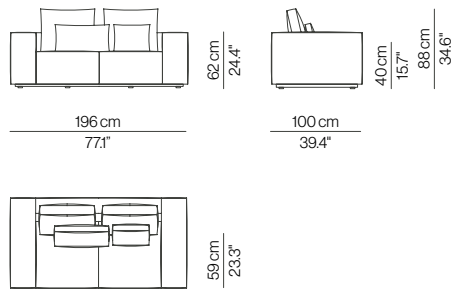

**Four Seater Sofa S4P**

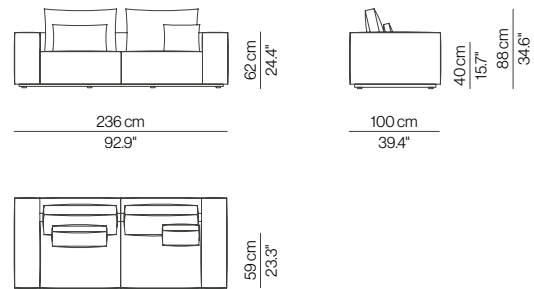

**Chaise Longue CHL1**

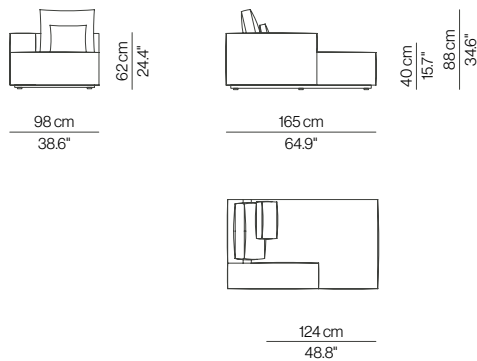

**Chaise Longue CHL2**

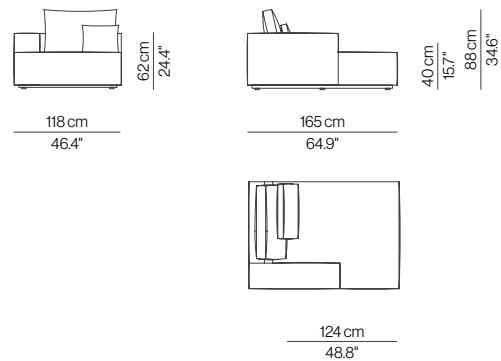

### Lateral Element MDB2

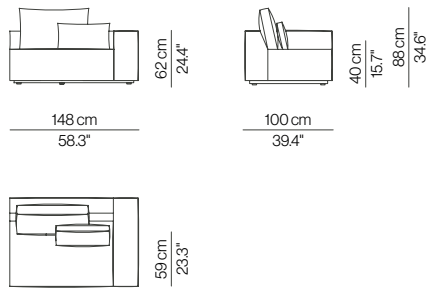

### Lateral Element MDB3

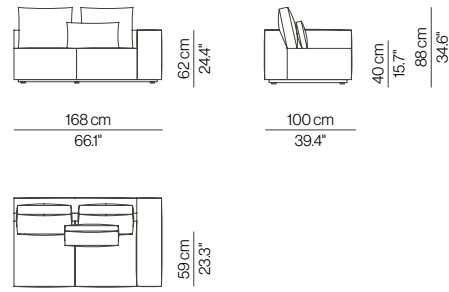

### Lateral Element MDB4

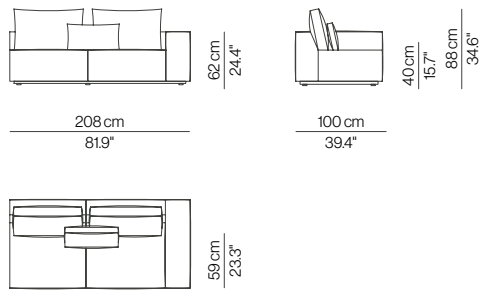

### Two Seater Central Element MD2P

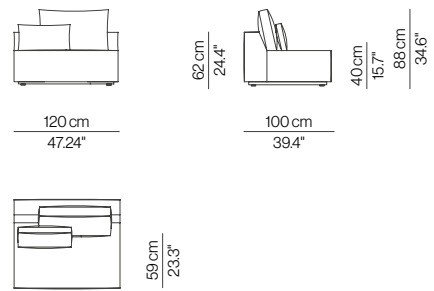

### Three Seater Central Element MD3P

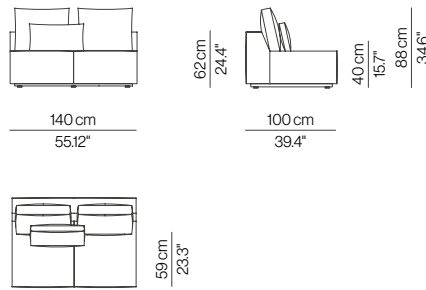

### Four Seater Central Element MD4P

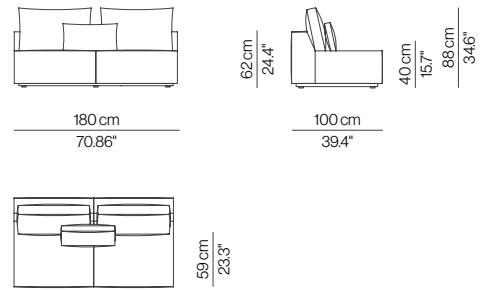

### Corner Element RI1P

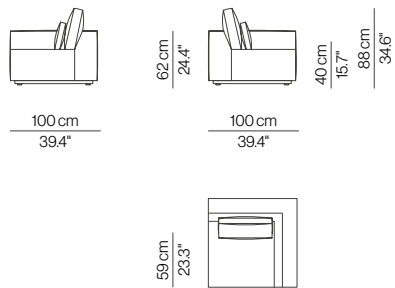

### Four Seater Corner Element RI2P

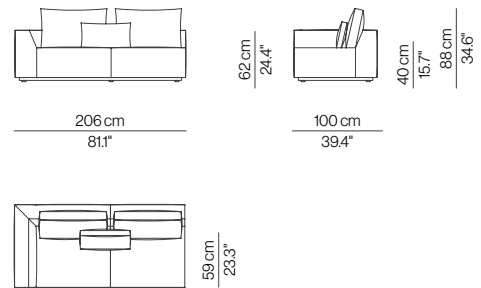

### Armchair B2E

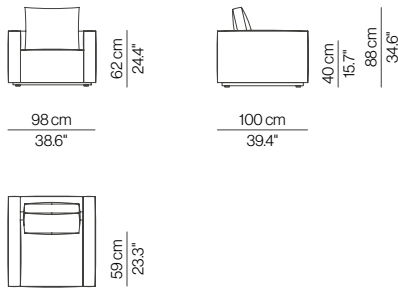

### Two Seater Sofa S2PE

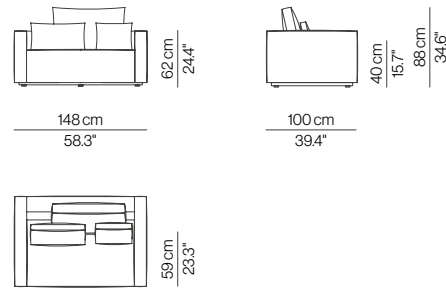

### Three Seater Sofa S3PE

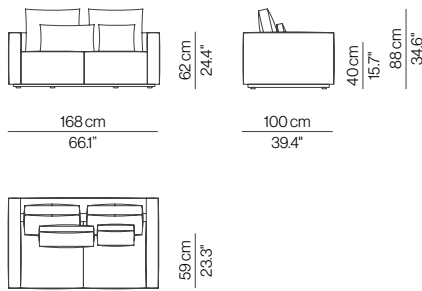

### Four Seater Sofa S4PE

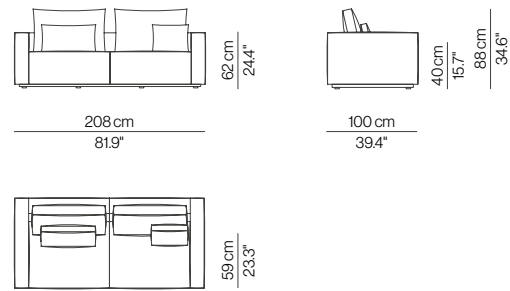

### Lateral Element MDB2E

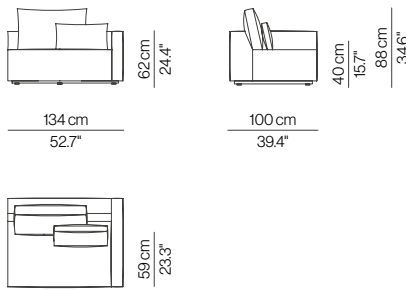

### Lateral Element MDB3E

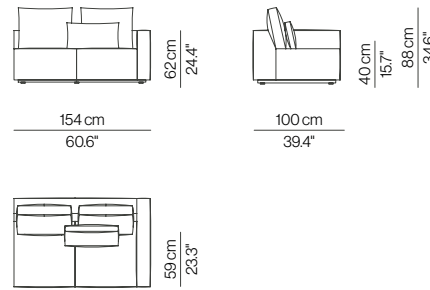

### Lateral Element MDB4E

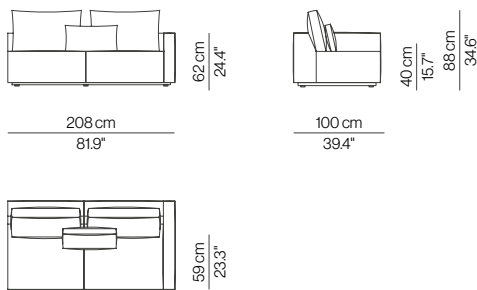

### PROABRZ

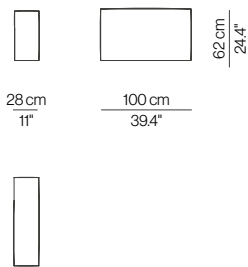

### PROABRZE

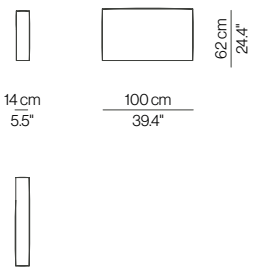

### Chaise Longue CHL1E

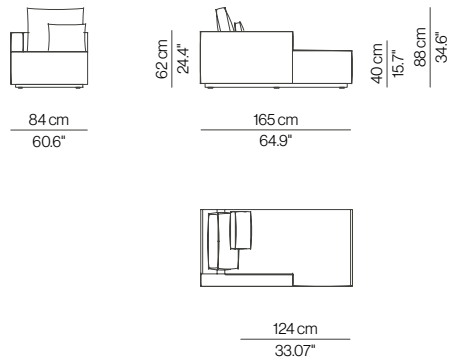

### Chaise Longue CHL2E

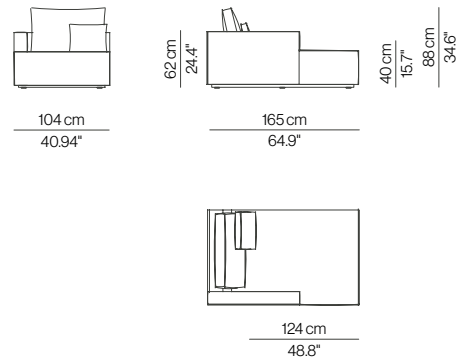

### Central Pouf IS90

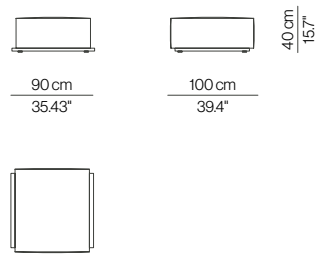

### Lateral Pouf ISB90

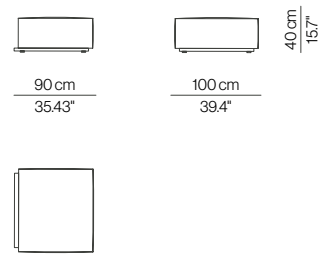

### Central Pouf IS120

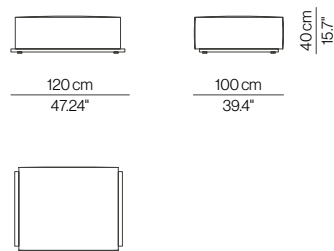

### Lateral Pouf ISB120

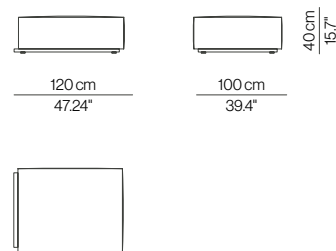

### Pouf PF140

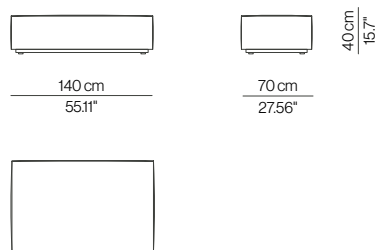

### Pouf PF70

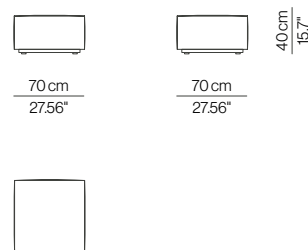



**Cushion CJRP80**

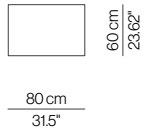

**Cushion CJRP60**

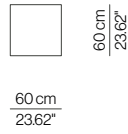

**Cushion CJREC**

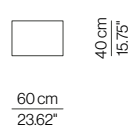

**Cushion CJRP80**

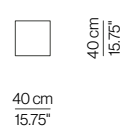

**SAM**

EN Reinforced beech wood curved integrated structure with reinforced Flanders pine wood seat structure. Solid metal legs (consult the finishes that are available). Back and arms made of CFC-free polyurethane foam that comes in different thicknesses. Lumber cushion made of goose feathers. Non-removable upholstery.

ES Estructura de madera curva de haya reforzada e integrada con bastidor de asiento de madera de pino Flandes reforzada. Pies metálicos macizos (consultar acabados disponibles). Respaldo y asientos compuestos por espumas de poliuretano libres de CFC de diferentes densidades. Cojines riñonera compuesto por plumas de oca. Tapizado fijo.

**Armchair B1**

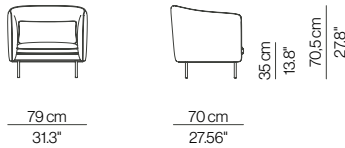

**Two Seater Sofa S2P**

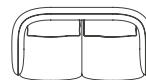
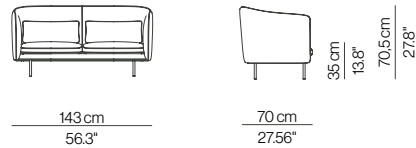

**Three Seater Sofa S3P**

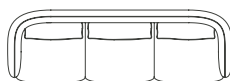
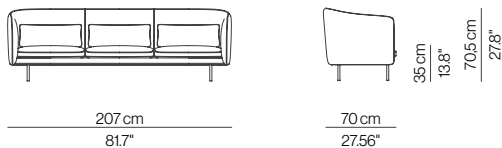

# SAL Y PIMIENTA

EN Metal frame cut by laser, with anticorrosion treatment; suspension by means of high-quality elastic belts. Metal legs made of solid rod with shiny nickel/ chrome finish. Seat made of a CFC-free high- quality polyurethane foam core, covered by a duvet filled with goose feathers and micro fibres. Backrest and auxiliary cushions made of goose feathers. Completely removable upholstery.

ES Estructura metálica de corte por láser con tratamiento anticorrosión; suspensión mediante cinchas elásticas de alta calidad. Pies metálicos de varilla maciza con acabado níquel/ cromo brillo. Asiento elaborado a partir de alma de espuma de poliuretano de alta calidad libre de CFC, envuelta por edredón de plumas de oca y micro fibras. Respaldos y cojines auxiliares realizados en plumas de oca. Totalmente desenfundable.

## Armchair B2

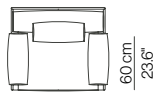
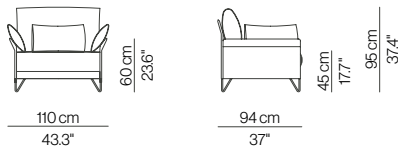

## Low seat LWS

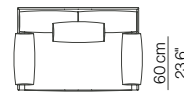
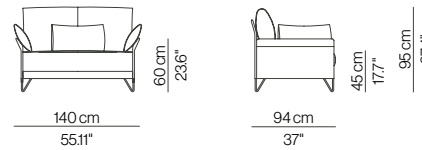

## Two Seater Sofa S2P

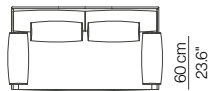
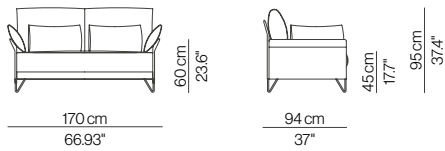

## Three Seater Sofa S3P

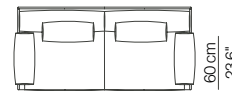
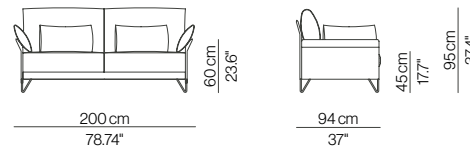

## Four Seater Sofa S4P

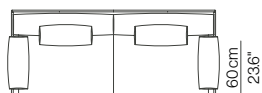
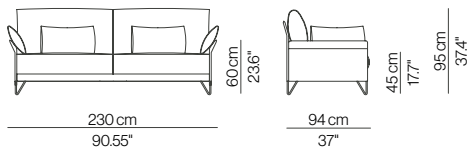

## Four Seater Sofa XL S4PXL

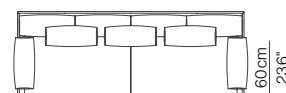
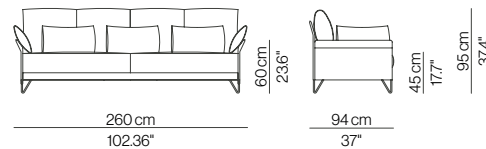

### Lateral Element MDB1

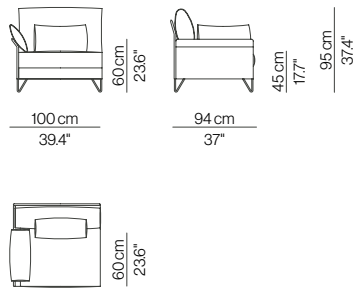

### Low Seat MDBLWS

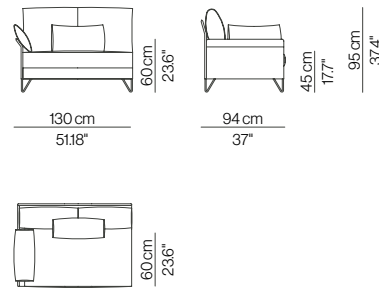

### Two Seater Lateral Element MDB2P

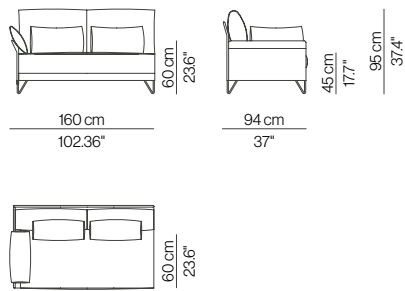

### Chaise Longue CH1

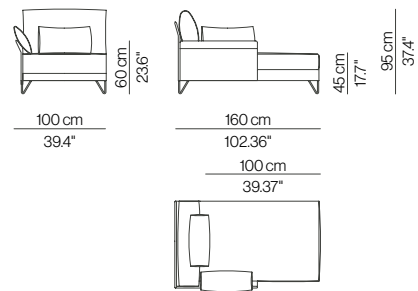

### High Back Low Seat LWS

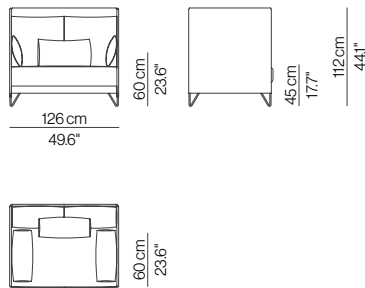

### High Back Three Seater Sofa S3P

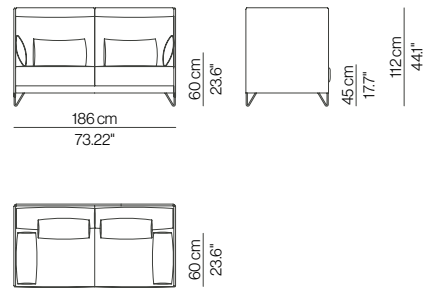

### High Back Four Seater Sofa XL S4PXL

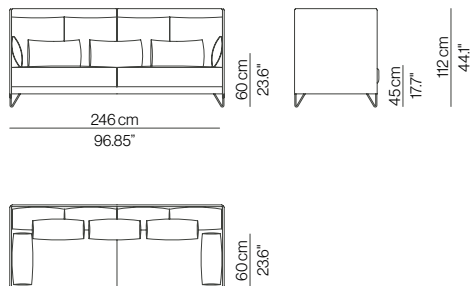

### Rectangular Pillow CJ/RIN

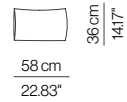

### Square Pillow CJ/CUA

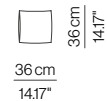

## WALLACE

EN Frame made of reinforced flanders pine wood; suspension by means of high quality elastic belts, both in seat and back. Monoblock upholstery in CFC-free polyurethane foam with different densities, covered by a duvet filled with goose feathers and micro fibres. Removable upholstery, except leather.

ES Estructura de madera de pino flandes reforzada; suspensión mediante cinchas elásticas de alta calidad tanto en asiento como en respaldo. Tapizado monobloque realizado en espuma de poliuretano libre de CFC y varias densidades, cubiertas por edredón de plumas de oca y micro fibras. Tapizado desenfundable, excepto piel.

### Armchair B1

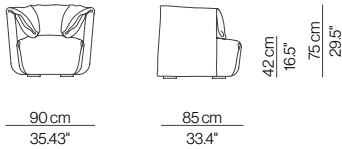

### Chaise Longue CHL2

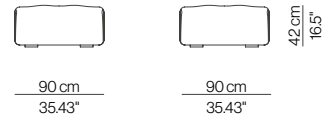

### Lateral Element MDB1

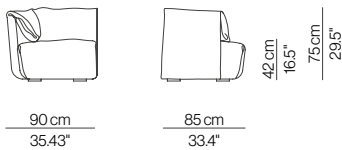

### Central Element MD1

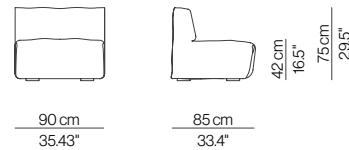

### Lateral Element MDB2

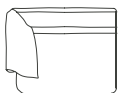
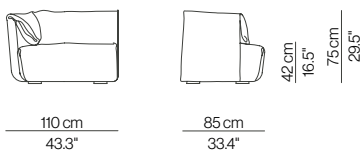

### Central Element MD2

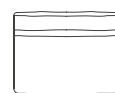
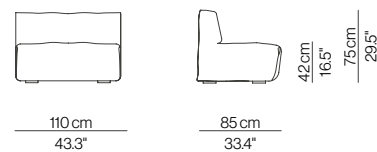

### Lateral Element MDB3

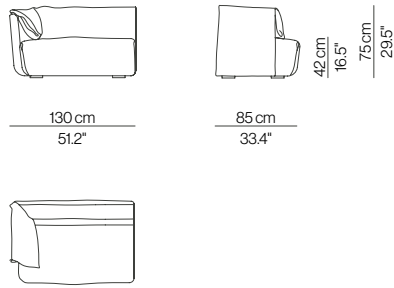

### Central Element MD3

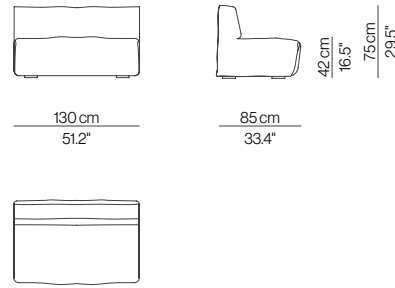

## ZONE

EN Frame made of reinforced flanders pine wood. Metal legs made of calibrated tube; available finishes: nickel/chrome shiny or matt finish, as well as customised RAL varnish (with surcharge). Monoblock seat and backrest made of CFC-free polyurethane foam, with different densities, covered by high-quality cotton. Non-removable upholstery.

ES Estructura de madera de pino flandes reforzada. Pies metálicos en tubo calibrado; acabados disponibles: tratamiento níquel/cromo brillo o mate, así como lacado en RAL cliente (con cargo adicional). Asientos y respaldos mono - bloque, elaborados en espumas de poliuretano de varias densidades y libres de CFC, recubiertas por boata de alta calidad. Tapizado fijo.

### SB1

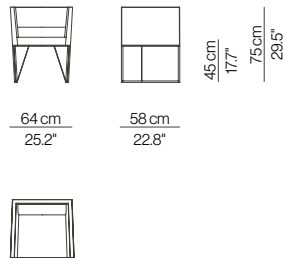

### Silla

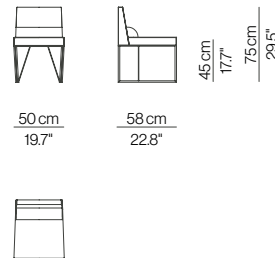

# PEROBELL

Designed by Arnau Reyna Studio

Copyright 2022 Perobell  
All rights reserved / Todos los derechos reservados.

Ildefons Cerdà, 14 - 08172 Sant Cugat del Vallès / [www.perobell.com](http://www.perobell.com) / email: [comercial@perobell.com](mailto:comercial@perobell.com)



[perobell.com](http://perobell.com)